



TECHNICAL DOCUMENTATION

ORIGINAL INSTRUCTION MANUAL

SINTESI MIXERS

Mori Tem S.r.l.

Via Leonardo da Vinci, 59 – 50028 TAVARNELLE V.P. (FI) Italy

Tel. 0039/55/8071568 – Fax 0039/55/8071293

E-mail: tem@tem.it – Web site: <http://www.tem.it>

VAT No./Taxpayer's Code 06464360483

LETTER ON DELIVERY

⇒Dear customer,

⇒We would like to inform you that the equipment covered by this manual has been designed, built and tested in accordance with mandatory applicable regulations, as specified in the enclosed Certificate of conformity.

⇒In this manual, we have described the parts of the machine, the dimensional and technical specifications of the same, providing instructions on how to use and service the equipment.

⇒We would like to confirm that the equipment represents no danger for the operator if the instructions provided are followed, when built into a line with a machine that has been declared compliant with MACHINERY DIRECTIVE 2006/42/EC on the condition that:

⇒ the protective systems installed are maintained intact;

⇒ the safety systems are left active;

⇒ operators are given the specific instructions in this manual;

⇒ periodic maintenance is performed and the condition of components is checked for any wear and damage;

⇒ the equipment is used within the functional parameters it was designed for and with machines it was designed and built to be used with;

Thank you for choosing our product, we wish you all the best in your profitable activity.

Signature

The descriptions and illustrations in this documentation are NOT binding.

Even the partial reproduction and disclosure of this document is forbidden without the specific prior authorisation of the author.

Any violations will be prosecuted in accordance with the Law.

The trade names and brands referred to in this manual are owned by the relevant Manufacturers.

INDEX

1.0	GENERAL FOREWORD	4
1.1	INTRODUCTION TO THE MANUAL.....	4
1.2	DECLARATION TO HAVE RECEIVED AND READ THE MANUAL	5
1.3	“CE” MARK.....	5
1.4	WARRANTY	6
1.5	REFERENCES	7
1.6	GLOSSARY	8
2.0	SAFETY	9
2.1	INTENDED USE	9
2.2	REASONABLY PREDICTABLE IMPROPER USE	9
2.3	USER'S RESPONSIBILITY	10
2.4	SPECIFIC SAFETY INSTRUCTIONS	10
2.5	JOB QUALIFICATIONS	11
2.6	WORKPLACES.....	12
2.7	PROTECTIVE MEASURES ADOPTED.....	15
2.8	CHECKING THE PROTECTIVE MEASURES ADOPTED.....	16
2.9	PROTECTIVE MEASURES THAT COME UNDER THE USER'S RESPONSIBILITY	18
2.10	USING PPE	21
2.11	WARNINGS ON RESIDUAL RISKS	22
3.0	PRESENTATION AND DESCRIPTION OF THE PLANT	43
3.1	MAIN PARTS OF THE PLANT	43
3.1.1	OVERALL DIMENSIONS.....	43

1.0 GENERAL FOREWORD

This manual has been drawn up to provide a simple and clear guide for machine installers, operators and maintenance technicians.

We recommend reading the instructions carefully before starting any operations for the first time.

While this manual has been drawn up with the greatest attention to detail, the user's experience is also of great importance and the user must be suitably qualified to perform the operations.

The instructions in this manual do not replace, integrate or change any regulations, laws and/or decrees in force where the equipment will be used.

Any reproduction, adaptation or translation of this manual without prior written consent, except in the cases provided for by copyright law, is forbidden.

The technical characteristics in the manual are not binding for the manufacturer and changes may be made to future supplies without prior warning.

TEM is constantly improving its products and reserves the right to make changes to the contents of this manual at any time without being obliged to make the same changes in the manuals of previous machines and/or plants, and/or update the same.

The customer will be informed in a timely manner of any changes in terms of machine safety.

TEM is pleased to receive any proposals the Customer may have to improve the machine, and will carefully consider application of the same.

1.1 Introduction to the manual

The importance of the manual

- 1) Consider the instruction manual an integral part of the product;
- 2) It provides guidelines for the installation, use, adjustment, servicing and disposal of the machine.

How to keep this manual

- 1) The instruction manual is considered an integral part of the machine, therefore it must be kept until the machine is disposed of;
- 2) Use the manual in a way which will not damage all or part of its contents;
- 3) Do not remove or rip out any of the manual's pages;
- 4) Keep the manual in a safe, dry place where it can easily be reached;
- 5) If the manual is lost or becomes illegible, ask the manufacturer or dealer for another copy, specifying the type of machine, providing the serial number and year of construction;
- 6) If the machine is sold, hired out, licensed for use or leasing, the instructions must be kept with the machine.

Using the manual

Before starting any work for which the machine was designed, the operator must have read the entire manual and fully understood all of the instructions, paying particular attention to the safety systems, the risk of noise emissions and general accident prevention rules and regulations provided for by international directives and the laws in force.

This manual is divided into specific sections as listed and described in the index of contents.

N.B. All the images in this manual are merely indicative; the manufacturer reserves the right to make changes to the machine without updating the images.

1.2 Declaration to have received and read the manual

The purchaser must complete every part of the “Declaration to have received and read the instruction manual” in the sheet enclosed with the manual for the warranty on the machine to be valid (from the date on the invoice); you must stamp this document with the Company stamp and it must be signed by the legal representative.

A copy of this form must be sent by fax (+39 - (0)55 - 80.71.293), email (in pdf format) to tem@tem.it or by ordinary post (TEM - Via Cimabue, 4-6 - 50028 Tavarnelle Val di Pesa (FI) - Italy) to TEM within 15 days of machine delivery.

If this document is not sent within the required time, or if it has not been completed, this represents an automatic declaration of the integrity of the manual and that the same has been read in full, releasing TEM from any related liability.

1.3 “CE” mark

The CE mark guarantees the equipment complies with the requirements of Machinery Directive 2006/42/EC.

Never remove the CE plate from its original position where it was affixed by the manufacturer.

Do not change or falsify the specifications on the same.

Do not clean the CE plate with sharp objects (ex.: wire brushes) as this could make it illegible.

If even some of the specifications on the CE plate are worn off or become illegible, we recommend requesting a replacement from the manufacturer, specifying the details in these instructions.

If the declaration of conformity enclosed with this manual cannot be found with the machine or has been lost, contact our offices for another copy specifying the serial number of the machine on the CE plate affixed to the same.

The “CE Declaration of conformity” is enclosed with this manual.

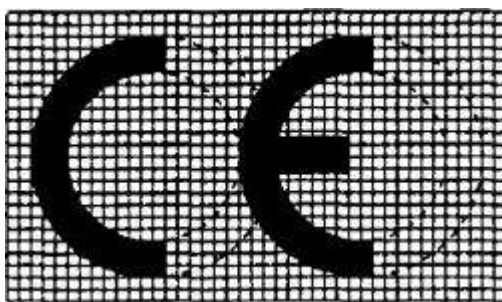

Figure 1 - Declaration of conformity on the machine

1.4 Warranty

The machine/s is/are supplied with a TEM 24-month warranty valid from the date of shipment (date on which the packing list was issued);

The warranty will expire 24 months after the date of shipment, and the cost of any repairs, replaced parts or customer service will be charged in full at our rates in force at that time;

The warranty does not cover parts made of glass, handles, fuses, aesthetic parts and plastic parts that can be removed, or parts and components such as microswitches, solenoid valves, etc.;

Furthermore, the warranty does not cover faults caused by tampering with the machine or work done by persons who are not TEM technicians or have not been authorised by TEM to do the work;

The TEM warranty gives the customer the right to request that components or parts with manufacturing flaws or which are faulty be replaced as soon as possible;

The warranty does not cover claims for compensation for damages or production stoppages. Transportation costs to and from our works in TAVARNELLE V.P., custom's duty, import/export costs and any other taxes, duties or costs incurred for delivering machine parts or components under warranty to our works and for delivering the same back to destination, will be paid by the customer;

Ordinary consumables such as lubricants and material required for cleaning, materials or parts subject to wear, and those damaged as a result of improper use of the machine are not covered by warranty;

The manufacturer, at their own discretion, reserves the right to repair or replace any faulty parts;

The warranty does not cover parts damaged during transportation, faults caused by unprofessional or incorrect installation or maintenance, incorrect electrical or air power use, carelessness, negligence or improper use, or in any case using the machine in a way which does not comply with the warnings and instructions in the instruction manual;

This warranty does not cover faults caused by improper or inadequate maintenance, unauthorised modifications or the use of the machine outside its design parameters;

The warranty is void if any modifications are made to the machine without the manufacturer's specific authorisation;

Any tampering with the machine, the unauthorised replacement of machine parts and the use of consumables not specified in the manual may cause an accident and releases the manufacturer from any civil and criminal liability;

The manufacturer is relieved of any liability for accidents which may involve operators as a consequence of performing operations that are not specified or are not recommended by the manual;

The warranty does not cover claims for compensation for damages or production stoppages.

N.B. There are no other expressed or implied warranties.

1.5 References

Manufacturer	<p>Mori Tem S.r.l. Via Leonardo da Vinci, 59 – 50028 TAVARNELLE V.P. (FI) - Italy Tel. 0039/55/8071568 – Fax 0039/55/8071293 E-mail: tem@tem.it – Web site: http://www.tem.it VAT No./Taxpayer's Code 06464360483</p>
Machine name	SINTESI MIXERS
Main standards of reference	<ul style="list-style-type: none"> ••Machinery Directive 2006/42/EC ••EMC Directive 2014/30/EC ••Low Voltage Directive 2014/35/EU ••UNI EN ISO 12100
Service centre	At manufacturer's plant (sole service centre)
Manual	March 2016
Revision	Rev.1

Table 1 – References

1.6 Glossary

Hazard/Danger: A potential source of injury or one which may be harmful to health;

Risk: A combination of the probability and the seriousness of an injury or harmful event, which may arise in a hazardous situation;

Danger zones: Any zone inside and/or near the machine where the presence of a person exposed constitutes a risk for the health and safety of the same person.

Exposed person: Any person who has their body or any part of their body in a danger zone.

Operator or machine operator: The person or persons with the job of installing, running, adjusting, servicing, cleaning, repairing and moving or doing maintenance on the machine.

Expert operator or qualified technician: Technician specifically authorised by the “Plant Manager” to set up and start, lubricate, grease, do routine and extraordinary maintenance on the machine.

Expert operator or qualified electrician: Technician specifically authorised by the “Plant Safety Manager” to set up and start, and do maintenance on the electrical parts of the machine.

Protective system: A device that reduces risk, on its own or with a protective cover.

Intended use: Use of the machine in compliance with the information in the instructions;

Reasonably predictable improper use: Any other use of the machine that is not specified in the instructions, but which may derive from easily predictable human behaviour.

2.0 SAFETY

2.1 Intended use

The intended use of the machine in compliance with the information in the instructions;

Only professional operators who have been trained to use the machine and who have read this manual must be allowed to use the machine.

Operators authorised to use the machine prepare the machine for service, start the machine and control and adjust the work parameters. All the operations must be performed in accordance with the operating commands and procedures described in the instruction manual.

2.2 Reasonably predictable improper use

Reasonably predictable improper use is considered any other use of the machine that is not specified in the instructions, but which may derive from easily predictable human behaviour.

On the basis of the manufacturer's experience, the machine should not be used in the following cases of improper use.

The manufacturer declines any responsibility in the case of improper use of the machine for which it was not designed and built.

The safety regulations and instructions in this manual must always be scrupulously observed. In particular, the operating limits specified in the manual must be observed. Unauthorised personnel must not be allowed near the equipment while it is being used.

Only suitably trained operators equipped with their own personal protective equipment should be allowed to use, service and repair the machine.

The manufacturer shall also be relieved of liability in the following cases:

- Incorrect installation;
- Improper machine/plant use;
- Tampering;
- Tampering with or bypassing the protective systems, also temporarily.
- Unauthorised modifications;
- The use of non-original spare parts;
- Non-compliance with the instructions provided;
- Non-observance of the maintenance schedule;
- Exceptional events;
- Use by operators who have not reached the minimum age required by the laws in force for work in the respective countries the machine is used in.
- Use by operators who have not been previously trained and informed of every risk and the residual machine risks as well as safety.
- Not using the Personal Protective Equipment (PPE) required by the instructions and the rules and regulations in force in the country the machine is used in.
- Using the machine also when it shows signs of malfunctioning or is partially faulty.

- Using the machine in a way which is not compliant with its limits of use (materials, speed, etc.).
- The simultaneous use of the machine by two or more operators who could put each other in danger, or put other exposed persons in danger.
- If used by the machine operator who fails to check that there are no exposed persons in the danger zones of the machine before using the controls.

Using the machine is forbidden:

- In places open to the public;
- In places where there is a risk of explosion and/or fire;
- In places contaminated by agents such as dust, acids, corrosive gasses, etc.;
- In places where there is the possibility of exposing it to radiation.

The work area must be cleaned with the machine stopped and with the electrical power switched off.

In normal conditions of use, removing the safety systems or protective covers is strictly prohibited.

2.3 User's responsibility

The Company using the machine must check that the operators doing the various jobs:

- have read and understood the use and maintenance instructions;
- are suitably trained for the jobs to be done, so they can do the same safely;
- have received specific training on how to use the machine properly;
- have been equipped with suitable personal protective equipment;
- are in a fit physical and mental condition (not under the effect of alcohol, medication or drugs).

2.4 Specific safety instructions

- The Machine must not be used for any other use except for that described in paragraph 3.2;
- Do not remove any safety system and do not attempt to deactivate or bypass the preventive and safety function of the same;
- Do not use any mechanical element to deactivate any kind of interlocking protective system;
- Always keep the machine serviced and in an efficient working condition;
- Regularly check (at least once a year) that none of the bolts on the load-bearing structures, covers, doors or motor connections have worked loose;
- Do not hold cloths, pieces of fabric or anything else near rotating parts of the machine.
- Only wash the machine with non-toxic products suitable for foodstuffs;
- Before doing any maintenance or removing the protective guards, it is obligatory to:
- Turn the electrical power off by opening the power line circuit breakers of both the main power board and the auxiliary power board, locking them with a padlock and giving the key of the padlock to the technicians doing the repairs;
- Check the mushroom-shaped emergency stop buttons have been pressed and locked;

- Place a sign on the power board warning “Machine being serviced”.
- Before starting the machine, check the electrical power line is protected by equipotential protection circuit breakers and the section and insulation of the conductors is that required by regulations;
- All the personnel who will use, service and install the machine must know the safety regulations and be in perfect physical and mental conditions;
- Anyone who is not specifically authorised to use the machine must be prevented from gaining access to the same;
- If any unusual noise or anomalous operation is noticed when using the machine, stop all moving parts and check to see where the problem is coming from. In any case, to prevent damage if mistakes are made when checking or controlling the machine, contact MORI TEM for explanations.

2.5 Job qualifications

In accordance with the manufacturer's risk assessment, the following table sums up how personnel must be qualified for the jobs done on the machine. The qualifications: “machine OPERATOR”, “MAINTENANCE TECHNICIAN”, “SPECIALIZED TECHNICIAN” and “MANUFACTURER'S TECHNICIAN”, are used to provide a clearer interpretation of the term “OPERATOR” as defined by Machinery Directive 2006/42/EC.

JOB	ORDINARY PERSON	OPERATOR	MAINTENANCE TECHNICIAN	SPECIALIZED TECHNICIAN	MANUFACTURER'S TECHNICIAN
Pass nearby or stop near the machine	☑	☑	☑	☑	☑
Transporting, unloading and storage	⊖	⊖	⊖	☑ (1)	⊖
Installation and assembly	⊖	⊖	⊖	☑	☑
Putting the machine into service	⊖	⊖	⊖	☑	☑
Use	⊖	☑	☑	☑	☑
Non-specialized maintenance (cleaning, inspecting)	⊖	☑	☑	☑	☑
Specialized maintenance (adjustments and replacing parts)	⊖	⊖	☑	☑	☑
Fault-finding and repairs	⊖	⊖	☑	☑	☑
Dismantling and scraping	⊖	⊖	⊖	☑ (2)	⊖
	A	B		C	
PERSONNEL TRAINING LEVEL					
A) UNTRAINED PERSONNEL B) TRAINED C) TRAINED (EXPERT TECHNICIAN)					

Key: ☑ Allowed ⊖ Not allowed

NOTE

(1): Technician specialized in moving loads.

(2): Technician specialized in waste disposal.

2.6 Workplaces

The work area must never be occupied in a way that interferes with the operator's free movement.

Operators must be able to gain immediate access to the machine in an emergency.

Access to the above area is forbidden for anyone who is not a machine operator, to prevent hazards caused by distraction or carelessness at work.

It is therefore recommended that the operator keeps the work area free of any tools and forbids any unauthorized access in order to work in safe operating conditions.

Workplace layout (OPERATOR)

Operators must only occupy the external areas of the machine shown in the following figure, and gain access to the zones protected by mobile protective covers to perform the operations described, using the appropriate openings left for this purpose.

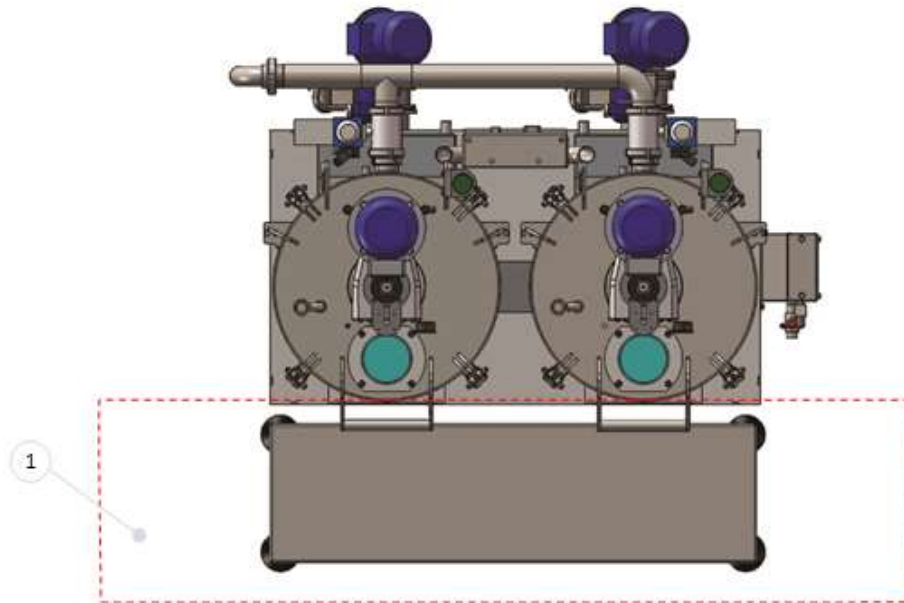

Ref.	Description of the work station
1	OPERATOR STATION.

Workplace layout (MAINTENANCE TECHNICIAN)

The maintenance technicians must perform the maintenance operations described in the areas of the machine shown in the following figure, and only gain access to the zones protected by fixed and mobile protective covers for the operations described after having disconnected the machine from all its energy sources and checked there is no residual energy accumulated anywhere in the machine (ex. charges in condensers, accumulated pressure, etc.).

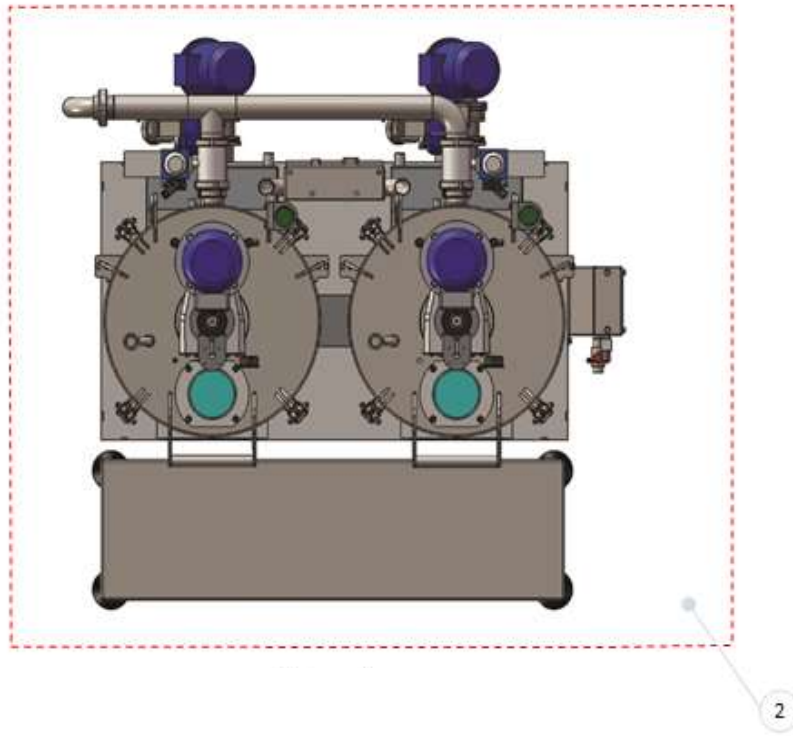

Ref.	Description of the work station
2	MACHINE External and internal area to which only specialized electrical and/or mechanical maintenance technicians can gain access.

2.7 Protective measures adopted

- This paragraph contains information on the protective measures adopted to eliminate or reduce the risks related to the machine.
-
- When a protective measure adopted does not completely eliminate a risk, but a lesser risk remains, this is described in the manual as a residual risk.

The protective measures adopted must be checked and effectively maintained during the entire working life of the machine.

- Perform the periodic checks described in the manual.
- It is forbidden to remove or even temporarily bypass the protective measures (ex. protective covers, photocell barriers, etc.).

Layout of protective measures adopted

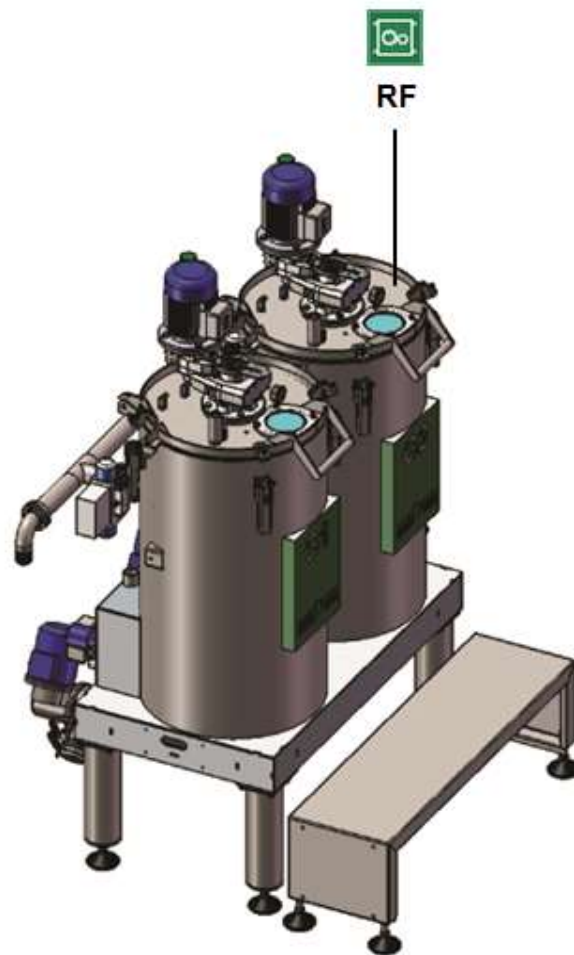

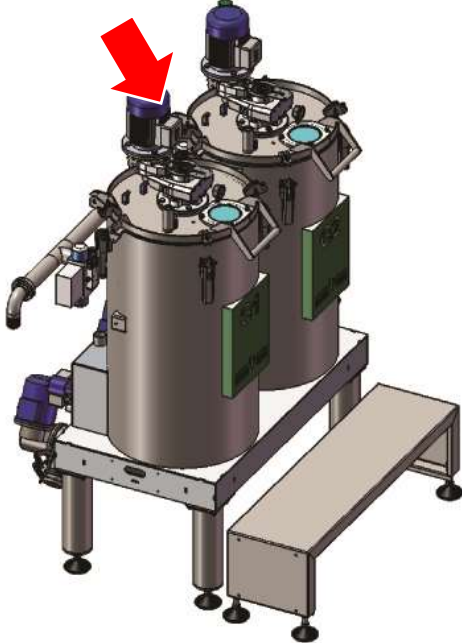

Table of protective measures

MEASURE	TYPE / Function	Photo / notes	CHECK
<p>RF</p> 	<p>FIXED PROTECTIVE COVER Protection over moving machine members consisting of fixed panels which can only be removed with tools (mesh and/or sheet steel).</p>	<p>MALAXER COVER FIXED PROTECTIVE COVER</p> 	<p>B</p>

2.8 Checking the protective measures adopted



In accordance with paragraph 1.7.1 of European Directive 2006/42/EC, the following information and warnings are provided on the machine.

The non-observance of any instructions because a safety label has become illegible, been lost or is simply not observed, can cause serious accidents.



- It is obligatory to know and observe the information and warnings on the machine in compliance with the meaning and the actions described in this instruction manual.
- The information and warnings on the machine must be kept in a good condition for the entire operational life of the machine; for this purpose some specific instructions for performing checks are given in the following paragraphs.
- The manufacturer will not be held responsible under any circumstances for the non-observance of the instructions on the machine and in the manuals supplied with the same.





Ref.	MEASURE	CHECKING METHOD	FREQUENCY
B	Fixed and/or movable protective covers	<ul style="list-style-type: none"> • Check if any part of the protective cover has been lost or damaged, in particular if this could reduce its effectiveness in terms of safety (ex. reduction of its resistance to impact, scratches on glass, etc.) • Replace parts subject to wear, in particular checking for any wear in joints or fastening points. • Check there is no damage caused by corrosion, temperature changes or chemicals. • Check no changes have been made to the safe distances and to the sizes of the openings. 	MONTHLY



Summary table of information and warnings

Ref.	PICTOGRAM	INSTRUCTIONS / WARNINGS
SL01		Maintain a safe distance to avoid dangerous direct or indirect contact with live parts. Observe safety regulations and use suitable Personal Protective Equipment (PPE) such as gloves offering protection against electric shocks.
SL02		Do NOT remove the protective covers protecting moving machine members. Only work on the machine with the protective covers removed if the machine has been disconnected from the electrical power line.
SL03		Beware of moving machine members when the machine is operating. Do NOT put your hands into the slots used to insert the product or near moving machine members.









2.9 Protective measures that come under the user's responsibility









Symbol	Description	Technical standard
	<p>Full body protection (1, 2, 3, 4, 5 6, 7)</p>	<p>1) UNI EN ISO13688 Protective clothing. General requirements.</p>
	<p>Always wear suitable protective clothing for the job being done. The column on the right lists the standards of reference on the basis of the required protection.</p>	<p>2) UNI EN ISO 342 Garments and clothing combinations for protection against cold 3) UNI EN ISO 11612 Garments that protect the body from heat and flame 4) UNI EN 943-1-2 Protective clothing against chemicals 5) UNI EN 13034 Protective clothing against liquid chemicals 6) UNI EN 1149 Protective Clothing - Electrostatic Properties 7) IEC EN 61482-1-2 Protective clothing against the thermal hazards of an electric arc</p>
	<p>Head protection</p>	<p>UNI EN 397 Industrial safety helmets</p>
	<p>Always wear a safety helmet when lifting and positioning the machine and in all cases when there is the risk of objects falling from a height.</p>	

Symbol	Description	Technical standard
	<p>Hand protection (1, 2, 3)</p>	<p>1) UNI EN 374 Protective gloves against chemicals and micro-organisms</p>
	<p>Always wear protective gloves whenever performing operations in which you could be exposed to risks. The column on the right lists the standards of reference on the basis of the required protection.</p>	<p>2) UNI EN 388 Gloves giving protection from mechanical and electrostatic risks</p> <p>3) UNI EN 407 Protective gloves against thermal risks</p>
	<p>Eye protection</p> <p>Always wear eye protection when performing operations in which there is the risk of materials being projected or exposure to splashes or jets of liquids.</p>	<p>UNI EN 166 Personal Eye-protection - Specifications</p>
	<p>Ear protection (1, 2)</p>	<p>1) UNI EN 352-1 Ear muffs</p>
	<p>Use personal protective equipment for the ears in accordance with the noise risk assessment in the workplace and the regulations in force in the country you are working in. The column on the right lists the standards of reference on the basis of the required protection.</p>	<p>2) UNI EN 352-2 Earplugs</p>
	<p>Foot protection (1, 2, 3)</p>	<p>1) UNI EN ISO 20345 Safety shoes</p>
	<p>Always wear safety footwear. The column on the right lists the standards of reference on the basis of the required protection.</p>	<p>2) UNI EN ISO 20346 Protective footwear</p> <p>3) UNI EN ISO 20347 Occupational footwear</p>

	<p>Respiratory protective devices (1, 2, 3, 4)</p> <hr/> <p>Always wear devices protecting the respiratory tract when cleaning the machine with solvents or chemical products.</p> <p>The column on the right lists the standards of reference on the basis of the required protection.</p>	<p>1) UNI EN 149 Filtering halfmasks to protect against particles</p> <p>2) UNI EN 405 Valved filtering half masks to protect against gases or gases and particles</p> <p>3) UNI EN 143 Particle filters</p> <p>4) UNI EN 14387 Gas filters and combined filters</p>
	<p>Protection against falls from a height (1, 2, 3, 4, 5, 6, 7, 8)</p> <hr/> <p>Always wear a safety body belt and harness when working at a height.</p> <p>The column on the right lists the standards of reference on the basis of the required protection.</p>	<p>1) UNI EN 353-1-2 Guided fall arrestors</p> <p>2) UNI EN 354 Lanyards</p> <p>3) UNI EN 355 Energy absorbers</p> <p>4) UNI EN 360 Guided type fall arresters including a flexible anchor line</p> <p>5) UNI EN 361 Full body harnesses</p> <p>6) UNI EN 363 Fall arrest systems</p> <p>7) UNI EN 795 Anchor devices</p>

2.10 Using PPE

Phase								
Operation								
Transportation								
Moving and transporting the machine	X (1)	X	X (2)			X (1)		
Assembling, installing and putting the machine into service								
Assembly/disassembly	X (1)		X (2)			X (1)		
Adjustments								
Washing the machine for the first time	X (1)		X (1)	X		X (1)		
Positioning the machine	X (1)		X (2)			X (1)		
Adjusting the nozzles	X (1)		X (2)			X (1)		
Use								
Starting the work cycle	X (1)		X (2)			X (1)		
Stopping the work cycle	X (1)		X (2)			X (1)		
Normal operation	X (1)		X (2)			X (1)		
Maintenance								
Various operations, inspections, cleaning, etc.	X (1)		X (2)	X		X (1)		
Working at a height	X (1)		X (2)			X (1)		X (5)
Lubricating/greasing	X (1)		X (1)	X		X (1)	X (1)	
Working on the electrical system	X (1)		X (2)			X (1)		
Working on the air system	X (1)		X (2)	X		X (1)		
Removing toxic/noxious substances after an accidental spillage	X (1)		X (1)	X		X (1)	X (1)	
Replacing worn parts and adjusting components	X (1)		X (2)			X (1)		
Replacing the water heating elements	X (1)		X (2) X (3)			X (1)		
Washing the machine	X (1)		X (1)	X		X (1)		
Fault-finding/anomalies								

Phase								
Operation								
Removing blockages	X (1)		X (1)	X				
Faulty components	X (1)					X (1)		
Escape and rescue	X (1)		X (2)			X (1)		
Dismantling, scrapping, disposal								
Waste disposal when scrapping	X (1)		X (1) X (2)	X		X (1)		

2.11 Warnings on residual risks

In compliance with paragraph 1.7.2 of European Directive 2006/42/EC, the remaining residual risks are described despite the fact that protective measures have been included in the design phase and additional protective measures have been applied.

The following paragraphs describe the residual risks in terms of the working life of the machine:

N.B.: When assessing the risks, the manufacturer, in compliance with the laws in force, did not allow for (not had any information on) any risks related to the workplace and specific work procedures adopted by the user.

N.B.: These abbreviations are used in the risk sheets in the following paragraphs:

OrdP = Ordinary Person
 SpecT = Specialized Technician
 ManT = Manufacturer's Technician
 OP = Operator
 MA = Maintenance technician
 Danger zones

Ref.	Description	Note
Z00	All zones	The risk may be present in all zones.
Z01	Electrical equipment	Electrical boards and boxes on board the machine containing live parts. Only specialised electrical technicians can work on electrical equipment. N.B.: The outer part of the electrical board can only be reached by the operator to turn the disconnecting switch and machine on/off and use the machine's controls.
Z02	Malaxer	The zone in which the olives are processed in the continuous vertical malaxer

Zone layout

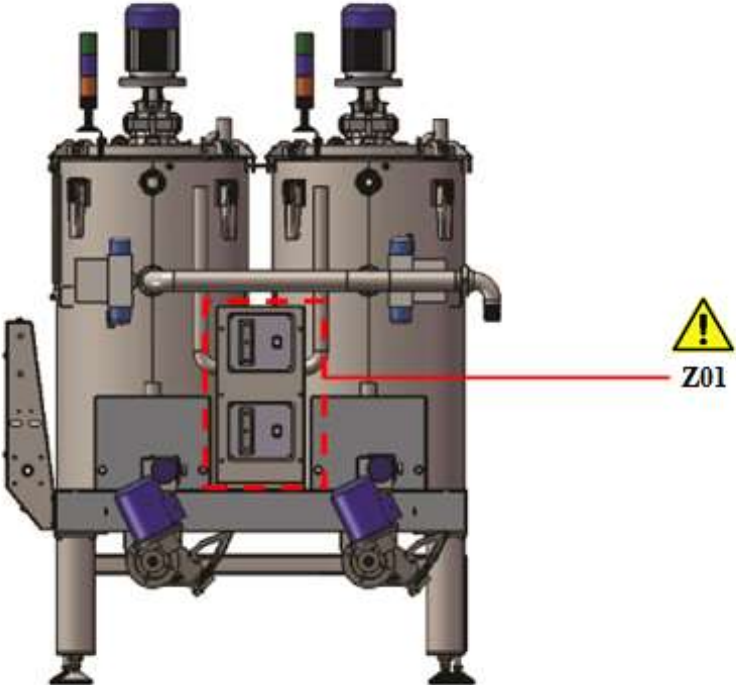
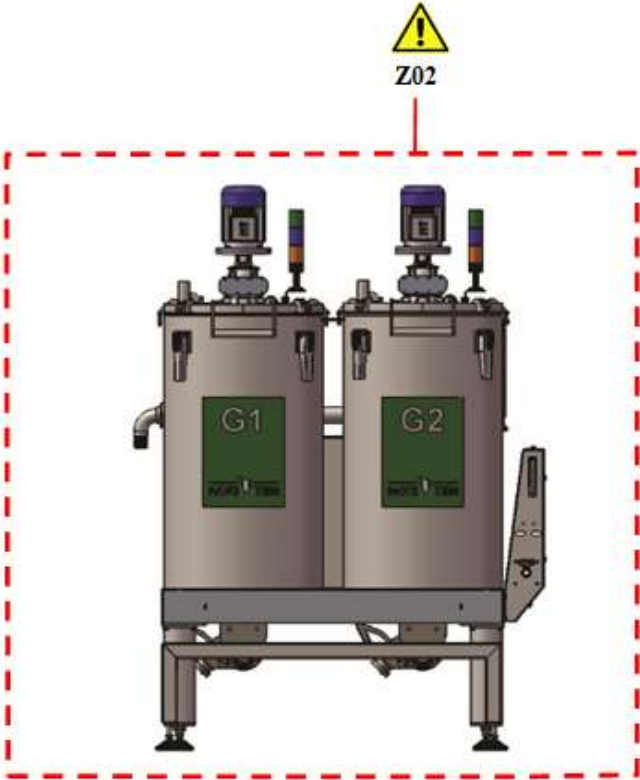

Any phase

Operation	Passing by or remaining near danger zones		
Person:	OrdP	Zones	Z00
Dangerous event	Various types of events depending on the work cycle of the machine and the work environment.		
Danger (Origin - Consequence)	Sources of danger on the machine or parts of the same.		
	Hazards deriving from the effects produced by sources of danger on the machine or parts of the same.		
ATTENTION	Residual risk		
	Ordinary persons who have not been trained may be exposed to various risks deriving both from the machine and the work environment.		
	Instructions		
	Ordinary persons who for whatever reason pass by or remain near machinery must always be accompanied by a trained person informed of the relevant risks, whose duty is to supervise ordinary persons. The employer must limit access for ordinary persons to danger zones using suitable company procedures.		

Transportation

Operation	Moving and transporting the machine		
Person:	SpecT	Zones	Z00
Dangerous event	Contact with sharp parts that could cut, sharp corners and edges of the machine.		
Danger (Origin - Consequence)	Sharp parts that could cut		
	Cutting of hands or arm		
ATTENTION	Residual risk		
	Exposure of maintenance technician and specialised technician to mechanical risks during transportation, assembly or disassembly.		
	Instructions		
	<ul style="list-style-type: none"> - The operation must only be performed by an expert person with the relevant know-how and experience, so they are able to analyse the risks and avoid the hazards that the job may entail. - Delimit the area of operations and forbid access to any unauthorised persons. - Follow the instructions for the operation to perform. - The employer should only use an expert person for the transportation, assembly or disassembly operations. - Do not perform any maintenance operations that are not described in the instructions supplied or operations which might require specific knowledge and the manufacturer's assistance. 		
	PPE		
	See chapter on "Safety", paragraph "Protective measures that come under the user's responsibility"		

Operation	Moving and transporting the machine		
Person:	SpecT	Zones	Z00
Dangerous event	Contact with sharp parts that could cut, sharp corners and edges of the machine.		
Danger (Origin - Consequence)	Sharp parts that could cut		
	Cutting of hands or arm		
ATTENTION	Residual risk		
	Exposure of maintenance technician and specialised technician to mechanical risks during transportation, assembly or disassembly.		
	Instructions		
	<ul style="list-style-type: none"> - The operation must only be performed by an expert person with the relevant know-how and experience, so they are able to analyse the risks and avoid the hazards that the job may entail. - Delimit the area of operations and forbid access to any unauthorised persons. - Follow the instructions for the operation to perform. - The employer should only use an expert person for the transportation, assembly or disassembly operations. - Do not perform any maintenance operations that are not described in the instructions supplied or operations which might require specific knowledge and the manufacturer's assistance. 		
	PPE		
	See chapter on "Safety", paragraph "Protective measures that come under the user's responsibility"		

Operation	Moving and transporting the machine		
Person:	SpecT	Zones	Z00
Dangerous event	Any falling load when moving also after a cable used to lift the load breaks.		
Danger (Origin - Consequence)	Falling objects		
	Crushing of body and head		
WARNING	Residual risk		
	The person moving and transporting the load may be exposed to the risk of moving parts falling.		
	Instructions		
	<ul style="list-style-type: none"> - The operation must only be performed by an expert person (EXP) with the relevant know-how and experience, so they are able to analyse the risks and avoid the hazards that the job may entail. - Delimit the area of operations and forbid access to any unauthorised persons. - Follow the instructions provided for lifting and moving the load. - The employer should only use an expert person for moving and transporting operations. 		
	PPE		
See chapter on “Safety”, paragraph “Protective measures that come under the user's responsibility”			

Assembling, installing and putting the machine into service

Operation	Assembly		
Person:	SpecT MA	Zones	Z00
Dangerous event	Contact with sharp elements or edges of the machine		
Danger (Origin - Consequence)	Sharp parts that could cut		
	Cutting of hands or arm		
ATTENTION	Residual risk		
	Exposure of maintenance technician and specialised technician to mechanical risks during transportation, assembly or disassembly.		
	Instructions		
	<ul style="list-style-type: none"> - The operation must only be performed by an expert person with the relevant know-how and experience, so they are able to analyse the risks and avoid the hazards that the job may entail. - Delimit the area of operations and forbid access to any unauthorised persons. - Follow the instructions for the operation to perform. - The employer should only use an expert person for the transportation, assembly or disassembly operations. - Do not perform any maintenance operations that are not described in the instructions supplied or operations which might require specific knowledge and the manufacturer's assistance. 		
	PPE		
	See chapter on "Safety", paragraph "Protective measures that come under the user's responsibility"		

Operation	Assembly		
Person:	SpecT ManT	Zones	Z01
Dangerous event	Direct or indirect contact with live parts		
Danger (Origin - Consequence)	- Contact with live parts (direct contact) - Contact with elements that may become live in the case of a fault (indirect contact)		
	Electrocution		
WARNING	Residual risk		
	Risk of electrocution due to direct or indirect contact with live parts.		
	Instructions		
	- Operations performed on electrical equipment both when live or when the power has been disconnected must only be performed by expert persons (EXP) and warned persons (WAP), in accordance with the definition in IEC 11-27. Standard IEC EN 60204-1 makes no distinction between work done on electrical equipment with the power disconnected or live, and therefore does not require a Person qualified for electrical work (PQUAL) to perform this work, in accordance with the definition of IEC 11-27.		
	- Work done on live parts inside the electrical board must only be performed after having disconnected the power and opened the door of the board, then reconnecting the power supplied to the equipment again by voluntarily turning the main switch ON.		
	PPE		
See chapter on “Safety”, paragraph “Protective measures that come under the user's responsibility”			

Operation	Assembly		
Person:	SpecT ManT	Zones	Z01
Dangerous event	Fire caused by electrical components and subsequent contact with flammable material		
Danger (Origin - Consequence)	Fire		
	Burning Burn		
WARNING	Residual risk		
	Risk of fire due to possible anomalies in the electrical system and subsequent contact with flammable material		
	Instructions		
	- The employer must provide fire-fighting equipment near the electrical boards		
	PPE		
See chapter on “Safety”, paragraph “Protective measures that come under the user's responsibility”			

Operation	Assembly		
Person:	SpecT MA	Zones	Z00
Dangerous event	Any falling load when assembling also after a cable used to lift the load breaks.		
Danger (Origin - Consequence)	Fall from a height Position high off the ground		
	Crushing of body and head		
WARNING	Residual risk		
	Exposure of maintenance technician and specialised technician to mechanical risks during transportation, assembly or disassembly.		
	Instructions		
	<ul style="list-style-type: none"> - The operation must only be performed by an expert person with the relevant know-how and experience, so they are able to analyse the risks and avoid the hazards that the job may entail. - Delimit the area of operations and forbid access to any unauthorised persons. - Follow the instructions for the operation to perform. - The employer should only use an expert person for the transportation, assembly or disassembly operations. - Do not perform any maintenance operations that are not described in the instructions supplied or operations which might require specific knowledge and the manufacturer's assistance. 		
	PPE		
See chapter on "Safety", paragraph "Protective measures that come under the user's responsibility"			

Operation	Assembly		
Person:	SpecT MA	Zones	Z01
Dangerous event	Wrong connections and/or section of the power cable and protective systems		
Danger (Origin - Consequence)	Electrocution		
	Contact with elements that may become live in the case of a fault (indirect contact)		
WARNING	Residual risk		
	Risk of electrocution caused by wrong connections made between the machine and the electrical power line.		
	Instructions		
	<ul style="list-style-type: none"> - The machine is usually shipped with the power cable connected, the section of which has been calculated on the basis of the length of the cable. When possible the cable is supplied with an industrial type socket (single phase and/or 3-phase). - If the cable isn't long enough to install the machine in the workplace, the final customer must replace the cable with one of a suitable length and section. - The machine must be connected to a power point with overcurrent cutouts on the power line, which will be installed by the user. - The machine is designed to be used in a "damp environment" and therefore all the connections must be made guaranteeing a minimum degree of protection of IP 55. - Follow the assembly instructions in the manufacturer's use and maintenance manual and the wiring diagrams. 		
	PPE		
	See chapter on "Safety", paragraph "Protective measures that come under the user's responsibility"		

Operation	Assembly		
Person:	SpecT MA	- Zones	Z01
Dangerous event	Wrong connections and/or section of the equipotential protection cable		
Danger (Origin - Consequence)	Electrocution		
	Contact with elements that may become live in the case of a fault (indirect contact)		
WARNING	Residual risk		
	Risk of electrocution caused by wrong connection of the machine to the earthing system.		
	Instructions		
	<ul style="list-style-type: none"> - The machine must be connected to the earthing system using the PE equipotential protection terminal in the electrical board, using an earth conductor of a suitable length and section, which must be installed by the user. - Follow the assembly instructions in the manufacturer's use and maintenance manual and the wiring diagrams. 		
	PPE		
See chapter on "Safety", paragraph "Protective measures that come under the user's responsibility"			

Adjustments

Operation	Washing the machine for the first time		
Person:	OP MA	Zones	Z02
Dangerous event	Failure to wash the machine for the first time (sanitization)		
Danger (Origin - Consequence)	Biological or microbiological agents (viruses or bacteria).		
	Poisoning, sensitization		
WARNING	Residual risk		
	Risk of contaminating foodstuffs if the machine isn't cleaned properly		
	Instructions		
	<ul style="list-style-type: none"> - It is obligatory to thoroughly clean the zone where the processed product will pass before putting the machine into service for the first time to remove any residues left from construction and protective substances used during transportation. - It is in any case necessary to thoroughly clean the machine, totally or partially dismantling parts of the same. Cleaning, while not strictly necessary for the machine to work, is essential to guarantee the quality of the processed product. - When cleaning, use a hose with a nozzle on the end to create a jet/spray of water under pressure. 		
	PPE		
	See chapter on "Safety", paragraph "Protective measures that come under the user's responsibility"		

Operation	Washing the machine for the first time		
Person:	OP MA	Zones	Z00
Dangerous event	Deriving from the type of substances used to clean the machine both due to the risk of contact with the skin and breathing in hazardous fumes (ex. accidentally inhaling or touching detergent mixes).		
Danger (Origin - Consequence)	Fluids		
	Poisoning, sensitization		
ATTENTION	Residual risk		
	The risk of sensitization deriving from the type of substances used to clean or lubricate the machine both due to the risk of contact with the skin and breathing in hazardous fumes (ex. accidentally inhaling or touching detergent mixes).		
	Instructions		
	Follow the instructions on the safety sheet of the product being used. The customer/employer must provide suitable PPE for the persons doing the cleaning or lubricating on the basis of the risks deriving from the use of any noxious substances.		
	PPE		
See chapter on “Safety”, paragraph “Protective measures that come under the user's responsibility”			

Use

Operation	Normal operation (operating the machine)		
Person:	OP	Zones	Z00 Z05
Dangerous event	Aerosol, spray of water and microscopic drops of oil produced during the work process.		
Danger (Origin - Consequence)	Aerosol		
	<ul style="list-style-type: none"> - Difficulty in breathing - Sensitisation 		
ATTENTION	Residual risk		
	Various risks deriving from materials and substances (mixed oil/water aerosol)		
	Instructions		
	<ul style="list-style-type: none"> - Use the machine in an environment where there is suitable ventilation that will decrease the presence of an aerosol of water and microscopic oil drops in the air. - Do not use the machine in closed, non-ventilated environments. 		
	PPE		
	See chapter on “Safety”, paragraph “Protective measures that come under the user's responsibility”		

Operation	Normal operation (operating the machine)		
Person:	OP	Zones	Z00
Dangerous event	Aerosol, spray of water and microscopic drops of oil produced during the work process.		
Danger (Origin - Consequence)	Aerosol		
	<ul style="list-style-type: none"> - Difficulty in breathing - Sensitisation 		
ATTENTION	Residual risk		
	Various risks deriving from materials and substances (mixed oil/water aerosol)		
	Instructions		
	<ul style="list-style-type: none"> - Use the machine in an environment where there is suitable ventilation that will decrease the presence of an aerosol of water and microscopic oil drops in the air. - Do not use the machine in closed, non-ventilated environments. 		
	PPE		
See chapter on “Safety”, paragraph “Protective measures that come under the user's responsibility”			

Fault-finding/anomalies

Operation	Faulty components		
Person:	SpecT ManT	Zones	Z01
Dangerous event	Direct or indirect contact with live parts		
Danger (Origin - Consequence)	Contact with live parts Contact with elements that may become live in the case of a fault		
	Electrocution		
WARNING	Residual risk		
	Risk of electrocution due to direct or indirect contact with live parts.		
	Instructions		
	<p>- Operations performed on electrical equipment both when live or when the power has been disconnected must only be performed by expert persons (EXP) and warned persons (WAP), in accordance with the definition in IEC 11-27. Standard IEC EN 60204-1 makes no distinction between work done on electrical equipment with the power disconnected or live, and therefore does not require a Person qualified for electrical work (PQUAL) perform this work, in accordance with the definition of IEC 11-27.</p> <p>- Work done on live parts inside the electrical board must only be performed after having disconnected the power and opened the door of the board, then reconnecting the power supplied to the equipment again by voluntarily turning the main switch ON.</p>		
	PPE		
	See chapter on “Safety”, paragraph “Protective measures that come under the user's responsibility”		

Operation	Faulty components		
Person:	SpecT ManT	Zones	Z01
Dangerous event	Direct or indirect contact with live parts		
Danger (Origin - Consequence)	Contact with live parts Contact with elements that may become live in the case of a fault		
	Electrocution		
WARNING	Residual risk		
	Risk of electrocution due to direct or indirect contact with live parts.		
	Instructions		
	<p>- Operations performed on electrical equipment both when live or when the power has been disconnected must only be performed by expert persons (EXP) and warned persons (WAP), in accordance with the definition in IEC 11-27. Standard IEC EN 60204-1 makes no distinction between work done on electrical equipment with the power disconnected or live, and therefore does not require a Person qualified for electrical work (PQUAL) perform this work, in accordance with the definition of IEC 11-27.</p> <p>- Work done on live parts inside the electrical board must only be performed after having disconnected the power and opened the door of the board, then reconnecting the power supplied to the equipment again by voluntarily turning the main switch ON.</p>		
	PPE		
	See chapter on “Safety”, paragraph “Protective measures that come under the user's responsibility”		

Dismantling, scrapping, disposal

Operation	Disassembly		
Person:	SpecT ManT	Zones	Z01
Dangerous event	Direct or indirect contact with live parts		
Danger (Origin - Consequence)	Contact with live parts Contact with elements that may become live in the case of a fault		
	Electrocution		
WARNING	Residual risk		
	Risk of electrocution due to direct or indirect contact with live parts.		
	Instructions		
	<p>- Operations performed on electrical equipment both when live or when the power has been disconnected must only be performed by expert persons (EXP) and warned persons (WAP), in accordance with the definition in IEC 11-27. Standard IEC EN 60204-1 makes no distinction between work done on electrical equipment with the power disconnected or live, and therefore does not require a Person qualified for electrical work (PQUAL) perform this work, in accordance with the definition of IEC 11-27.</p> <p>- Work done on live parts inside the electrical board must only be performed after having disconnected the power and opened the door of the board, then reconnecting the power supplied to the equipment again by voluntarily turning the main switch ON.</p>		
	PPE		
See chapter on “Safety”, paragraph “Protective measures that come under the user's responsibility”			

Operation	Disassembly		
Person:	SpecT ManT	Zones	Z01
Dangerous event	Direct or indirect contact with live parts		
Danger (Origin - Consequence)	Contact with live parts Contact with elements that may become live in the case of a fault		
	Electrocution		
WARNING	Residual risk		
	Risk of electrocution due to direct or indirect contact with live parts.		
	Instructions		
	<p>- Operations performed on electrical equipment both when live or when the power has been disconnected must only be performed by expert persons (EXP) and warned persons (WAP), in accordance with the definition in IEC 11-27. Standard IEC EN 60204-1 makes no distinction between work done on electrical equipment with the power disconnected or live, and therefore does not require a Person qualified for electrical work (PQUAL) perform this work, in accordance with the definition of IEC 11-27.</p> <p>- Work done on live parts inside the electrical board must only be performed after having disconnected the power and opened the door of the board, then reconnecting the power supplied to the equipment again by voluntarily turning the main switch ON.</p>		
	PPE		
	See chapter on “Safety”, paragraph “Protective measures that come under the user's responsibility”		

Operation	Disassembly		
Person:	SpecT ManT	Zones	Z01
Dangerous event	Direct or indirect contact with live parts		
Danger (Origin - Consequence)	Contact with live parts Contact with elements that may become live in the case of a fault		
	Electrocution		
WARNING	Residual risk		
	Risk of electrocution due to direct or indirect contact with live parts.		
	Instructions		
	<p>- Operations performed on electrical equipment both when live or when the power has been disconnected must only be performed by expert persons (EXP) and warned persons (WAP), in accordance with the definition in IEC 11-27. Standard IEC EN 60204-1 makes no distinction between work done on electrical equipment with the power disconnected or live, and therefore does not require a Person qualified for electrical work (PQUAL) perform this work, in accordance with the definition of IEC 11-27.</p> <p>- Work done on live parts inside the electrical board must only be performed after having disconnected the power and opened the door of the board, then reconnecting the power supplied to the equipment again by voluntarily turning the main switch ON.</p>		
	PPE		
	See chapter on “Safety”, paragraph “Protective measures that come under the user's responsibility”		

3.0 PRESENTATION AND DESCRIPTION OF THE PLANT

3.1 Main parts of the plant

3.1.1 Overall dimensions

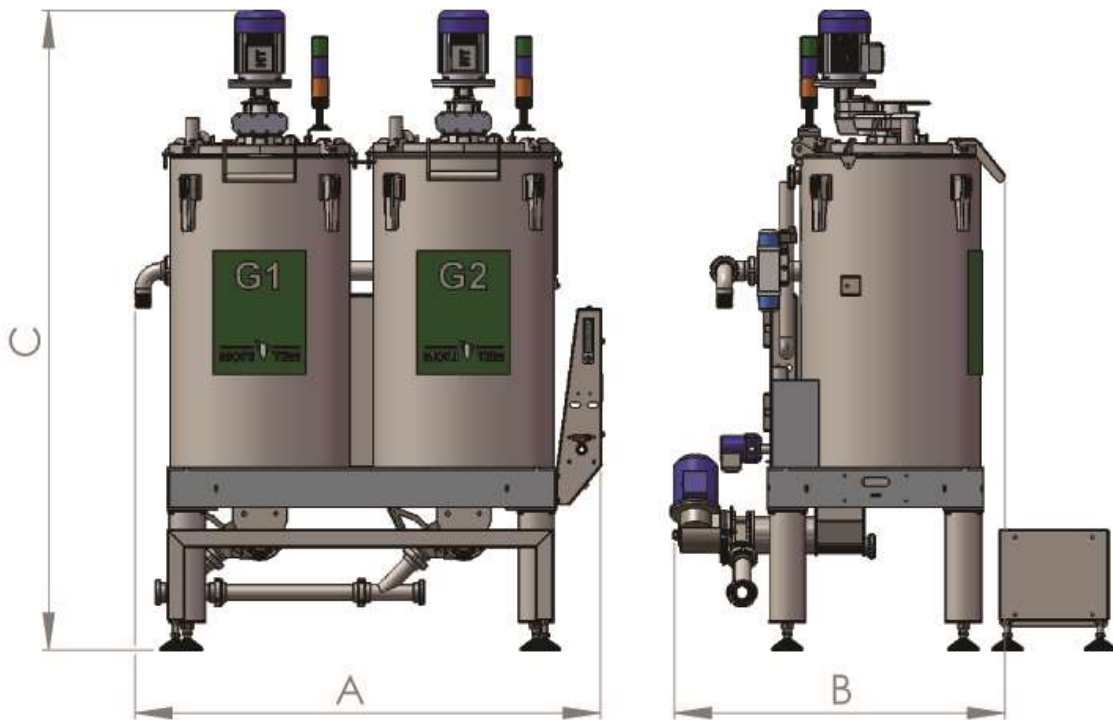

Figure 2

MODEL	DIMENSIONS (mm)	WEIGHT (Kg)	Ø STIRRE (mm)	POWER (kW)
2GV_100	A B C 1250 1000 1900	340	500	3
2GV_150	A B C 1250 1000 2000	380	500	4
2GV_200	A B C 1250 1000 2150	400	500	4
2GV_300	A B C 1650 1100 2150	450	660	5
3GV_200	A B C 1250 1000 2150	530	500	6

Table 2

1. Paste inlet
2. Stirrer motor
3. Vacuum gauge
4. Stirrer
5. Washing water inlet (if present)
6. Paste immission pump
7. Paste inlet electrovalve

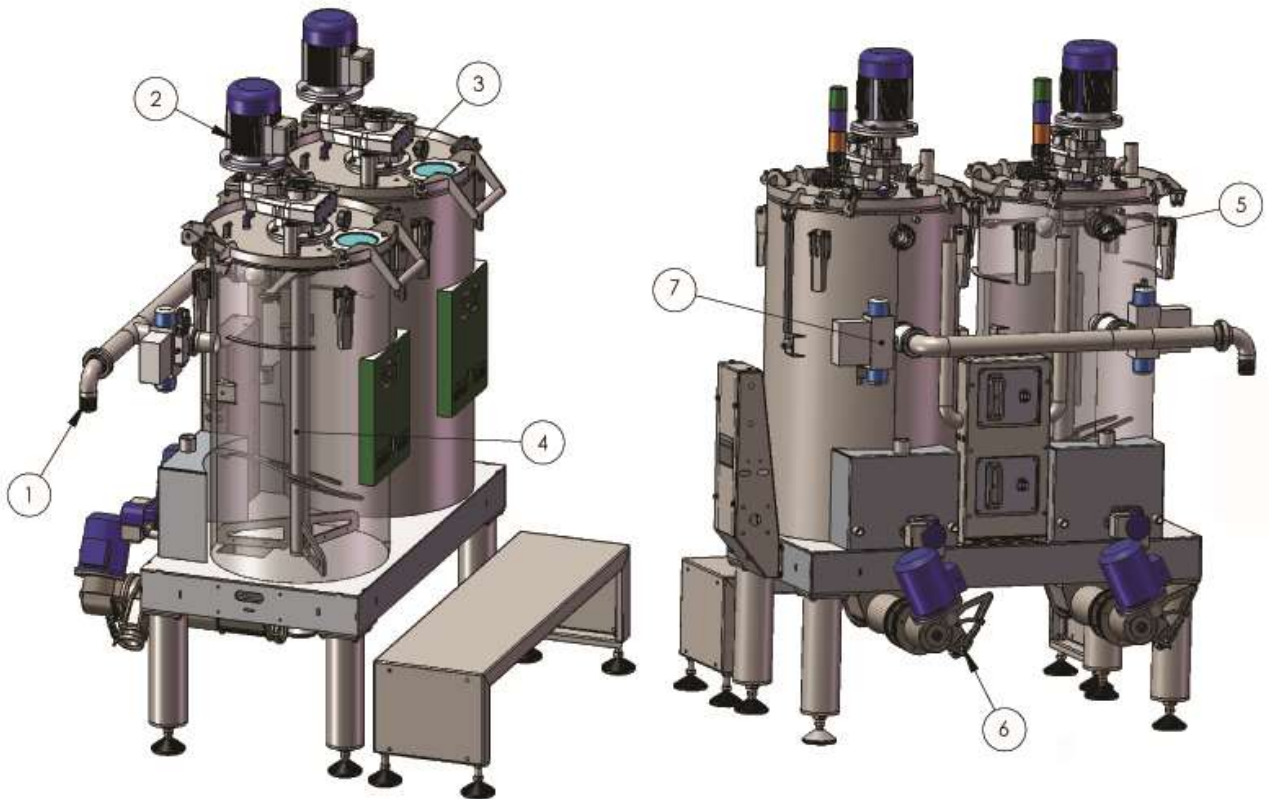

Figure 3

8. Flowmeter
9. Flowmeter water connection

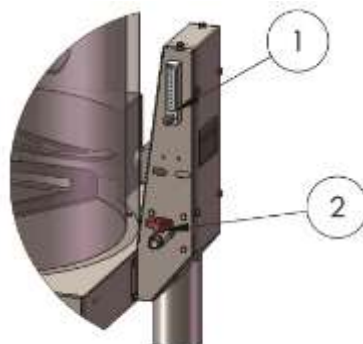

Figure 4

1. Vacuum gauge
2. Mixer working phases column
3. Level sensor
4. Stirrer motor
5. Thermo glass
6. Safety valve
7. Vacuum electrovalve
8. Vacuum/pressure transducer

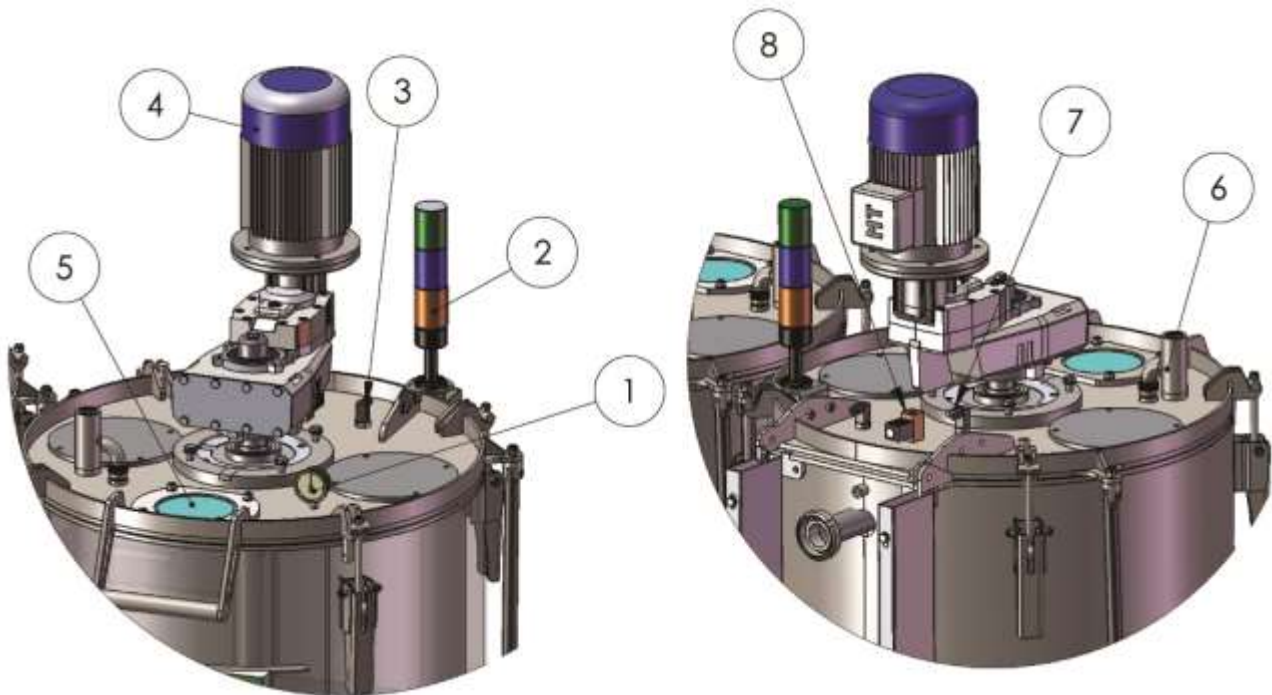

Figure 5

The malaxer heating water jacket must be filled with water using the valve under the malaxer (Figure 6)



Figure 6

Working phases column



Malaxer status signal lamp	
ORANGE	: paste inlet (same colour as general electric control board)
WHITE	: malaxer full / paste inside
BLUE	: paste (same colour as general electric control board)
GREEN	: extraction active (same colour as general electric control board)

Figure 7

Stopping and cleaning

(N.B. These instructions are for a plant with a crusher, malaxers and a decanter. If present, see the instructions provided with your plant)

Stopping

Before the daily washing of the plant can be done, you must drain all the oil in the decanter.

1. Once all the paste has been processed, open the water inlet valve on the decanter for 5-10 seconds, then close it again for the same time. Repeat this operation until no more oil flows out of the decanter.
2. At this point, leave the valve open for about 15-20 seconds, then close it again.
3. Wait until all the liquids have drained out of the decanter.

Washing

1. Turn the entire plant OFF except for the selector WASTE. When the decanter has come to a complete stop, liquids will drain out.
2. Open the cover of the decanter and wash with water. When you have finished cleaning, turn the decanter by hand in both directions to drain all the water.
3. Disconnect the paste inlet pipe from the decanter and clean the inside thoroughly with water.
4. Start the entire plant again except for the selectors DECANTER and WASTE.
5. Pipe water into the hopper of the crusher and wait until it flows clean out of the malaxer pump.
6. Turn the entire machine OFF.
7. Open the crusher and clean inside by hand

8. Wash inside the crusher, the impeller, the blades, the cleaner and grating, thoroughly. There must be no traces of paste inside.
9. Close the crusher completely.
10. Open the cover of the malaxer.
11. Wash the inside of the malaxer thoroughly with water. There must be no traces of paste on any parts of the walls.
12. Close the cover again after washing thoroughly.
13. Turn the entire plant ON except for the selectors DECANTER and WASTE, keeping selectors EXTRACTION G1 and then G2 turned to ON to drain the water out of the malaxer.

MIXER WATER TEMPERATURE REGULATOR



Figure 8

IMPORTANT: The default value is “SP 020”.

- Press (P) on the viewer. On the display you will see the value “SP 020”.
- Push arrow keys up or down to set the desired value.
- Press (P) to confirm this value

IMPORTANT: This regulation acts on the electric boiler to heat the paste, when it reaches the value set the boiler automatically stops due to the inductive factor and depending on the environmental temperature, the paste temperature raise of further 4°-5° C.