



TECHNICAL DOCUMENTATION

ORIGINAL INSTRUCTION MANUAL

FR.350 CRUSHER

Mori Tem S.r.l.

Via Leonardo da Vinci, 59 – 50028 TAVARNELLE V.P. (FI) Italy

Tel. 0039/55/8071568 – Fax 0039/55/8071293

E-mail: tem@tem.it – Web site: <http://www.tem.it>

VAT No./Taxpayer's Code 06464360483

LETTER ON DELIVERY

⇒Dear customer,

⇒We would like to inform you that the equipment covered by this manual has been designed, built and tested in accordance with mandatory applicable regulations, as specified in the enclosed Certificate of conformity.

⇒In this manual, we have described the parts of the machine, the dimensional and technical specifications of the same, providing instructions on how to use and service the equipment.

⇒We would like to confirm that the equipment represents no danger for the operator if the instructions provided are followed, when built into a line with a machine that has been declared compliant with MACHINERY DIRECTIVE 2006/42/EC on the condition that:

⇒ the protective systems installed are maintained intact;

⇒ the safety systems are left active;

⇒ operators are given the specific instructions in this manual;

⇒ periodic maintenance is performed and the condition of components is checked for any wear and damage;

⇒ the equipment is used within the functional parameters it was designed for and with machines it was designed and built to be used with;

Thank you for choosing our product, we wish you all the best in your profitable activity.

Signature

The descriptions and illustrations in this documentation are NOT binding.

Even the partial reproduction and disclosure of this document is forbidden without the specific prior authorisation of the author.

Any violations will be prosecuted in accordance with the Law.

The trade names and brands referred to in this manual are owned by the relevant Manufacturers.

INDEX

1.0	GENERAL FOREWORD	4
1.1	INTRODUCTION TO THE MANUAL.....	4
1.2	DECLARATION TO HAVE RECEIVED AND READ THE MANUAL	5
1.3	“CE” MARK.....	5
1.4	WARRANTY	6
1.5	REFERENCES	7
1.6	GLOSSARY	8
2.0	SAFETY	9
2.1	INTENDED USE	9
2.2	REASONABLY PREDICTABLE IMPROPER USE	9
2.3	USER'S RESPONSIBILITY	10
2.4	SPECIFIC SAFETY INSTRUCTIONS	10
2.5	JOB QUALIFICATIONS	11
2.6	WORKPLACES.....	12
2.7	PROTECTIVE MEASURES ADOPTED.....	15
2.8	CHECKING THE PROTECTIVE MEASURES ADOPTED	17
2.9	PROTECTIVE MEASURES THAT COME UNDER THE USER'S RESPONSIBILITY	18
2.10	USING PPE	21
2.11	WARNINGS ON RESIDUAL RISKS	22
3.0	PRESENTATION AND DESCRIPTION OF THE PLANT	45
3.1	MAIN PARTS OF THE PLANT	45
3.1.1	NAMEPLATE.....	45
3.1.2	OVERALL DIMENSIONS.....	45
3.2	GENERAL SAFETY REGULATIONS.....	49
3.2.1	<i>Illegal or improper use, or use which is not permitted</i>	49
3.2.2	<i>User's responsibility</i>	49
3.2.3	<i>Specific safety instructions</i>	50
4.0	INSTRUCTION MANUAL	51
4.1	PREPARATIONS FOR USING THE MACHINE	51
4.1.1	<i>Environmental operating conditions</i>	51
4.2	INSTRUCTIONS.....	54

1.0 GENERAL FOREWORD

This manual has been drawn up to provide a simple and clear guide for machine installers, operators and maintenance technicians.

We recommend reading the instructions carefully before starting any operations for the first time.

While this manual has been drawn up with the greatest attention to detail, the user's experience is also of great importance and the user must be suitably qualified to perform the operations.

The instructions in this manual do not replace, integrate or change any regulations, laws and/or decrees in force where the equipment will be used.

Any reproduction, adaptation or translation of this manual without prior written consent, except in the cases provided for by copyright law, is forbidden.

The technical characteristics in the manual are not binding for the manufacturer and changes may be made to future supplies without prior warning.

TEM is constantly improving its products and reserves the right to make changes to the contents of this manual at any time without being obliged to make the same changes in the manuals of previous machines and/or plants, and/or update the same.

The customer will be informed in a timely manner of any changes in terms of machine safety.

TEM is pleased to receive any proposals the Customer may have to improve the machine, and will carefully consider application of the same.

1.1 Introduction to the manual

The importance of the manual

- 1) Consider the instruction manual an integral part of the product;
- 2) It provides guidelines for the installation, use, adjustment, servicing and disposal of the machine.

How to keep this manual

- 1) The instruction manual is considered an integral part of the machine, therefore it must be kept until the machine is disposed of;
- 2) Use the manual in a way which will not damage all or part of its contents;
- 3) Do not remove or rip out any of the manual's pages;
- 4) Keep the manual in a safe, dry place where it can easily be reached;
- 5) If the manual is lost or becomes illegible, ask the manufacturer or dealer for another copy, specifying the type of machine, providing the serial number and year of construction;
- 6) If the machine is sold, hired out, licensed for use or leasing, the instructions must be kept with the machine.

Using the manual

Before starting any work for which the machine was designed, the operator must have read the entire manual and fully understood all of the instructions, paying particular attention to the safety systems, the risk of noise emissions and general accident prevention rules and regulations provided for by international directives and the laws in force.

This manual is divided into specific sections as listed and described in the index of contents.

N.B. All the images in this manual are merely indicative; the manufacturer reserves the right to make changes to the machine without updating the images.

1.2 Declaration to have received and read the manual

The purchaser must complete every part of the “Declaration to have received and read the instruction manual” in the sheet enclosed with the manual for the warranty on the machine to be valid (from the date on the invoice); you must stamp this document with the Company stamp and it must be signed by the legal representative.

A copy of this form must be sent by fax (+39 - (0)55 - 80.71.293), email (in pdf format) to tem@tem.it or by ordinary post (TEM - Via Cimabue, 4-6 - 50028 Tavarnelle Val di Pesa (FI) - Italy) to TEM within 15 days of machine delivery.

If this document is not sent within the required time, or if it has not been completed, this represents an automatic declaration of the integrity of the manual and that the same has been read in full, releasing TEM from any related liability.

1.3 “CE” mark

The CE mark guarantees the equipment complies with the requirements of Machinery Directive 2006/42/EC.

Never remove the CE plate from its original position where it was affixed by the manufacturer.

Do not change or falsify the specifications on the same.

Do not clean the CE plate with sharp objects (ex.: wire brushes) as this could make it illegible.

If even some of the specifications on the CE plate are worn off or become illegible, we recommend requesting a replacement from the manufacturer, specifying the details in these instructions.

If the declaration of conformity enclosed with this manual cannot be found with the machine or has been lost, contact our offices for another copy specifying the serial number of the machine on the CE plate affixed to the same.

The “CE Declaration of conformity” is enclosed with this manual.

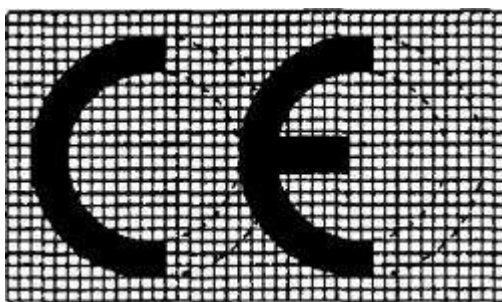

Figure 1 - Declaration of conformity on the machine

1.4 Warranty

The machine/s is/are supplied with a TEM 24-month warranty valid from the date of shipment (date on which the packing list was issued);

The warranty will expire 24 months after the date of shipment, and the cost of any repairs, replaced parts or customer service will be charged in full at our rates in force at that time;

The warranty does not cover parts made of glass, handles, fuses, aesthetic parts and plastic parts that can be removed, or parts and components such as microswitches, solenoid valves, etc.;

Furthermore, the warranty does not cover faults caused by tampering with the machine or work done by persons who are not TEM technicians or have not been authorised by TEM to do the work;

The TEM warranty gives the customer the right to request that components or parts with manufacturing flaws or which are faulty be replaced as soon as possible;

The warranty does not cover claims for compensation for damages or production stoppages. Transportation costs to and from our works in TAVARNELLE V.P., custom's duty, import/export costs and any other taxes, duties or costs incurred for delivering machine parts or components under warranty to our works and for delivering the same back to destination, will be paid by the customer;

Ordinary consumables such as lubricants and material required for cleaning, materials or parts subject to wear, and those damaged as a result of improper use of the machine are not covered by warranty;

The manufacturer, at their own discretion, reserves the right to repair or replace any faulty parts;

The warranty does not cover parts damaged during transportation, faults caused by unprofessional or incorrect installation or maintenance, incorrect electrical or air power use, carelessness, negligence or improper use, or in any case using the machine in a way which does not comply with the warnings and instructions in the instruction manual;

This warranty does not cover faults caused by improper or inadequate maintenance, unauthorised modifications or the use of the machine outside its design parameters;

The warranty is void if any modifications are made to the machine without the manufacturer's specific authorisation;

Any tampering with the machine, the unauthorised replacement of machine parts and the use of consumables not specified in the manual may cause an accident and releases the manufacturer from any civil and criminal liability;

The manufacturer is relieved of any liability for accidents which may involve operators as a consequence of performing operations that are not specified or are not recommended by the manual;

The warranty does not cover claims for compensation for damages or production stoppages.

N.B. There are no other expressed or implied warranties.

1.5 References

Manufacturer	<p>Mori Tem S.r.l. Via Leonardo da Vinci, 59 – 50028 TAVARNELLE V.P. (FI) - Italy Tel. 0039/55/8071568 – Fax 0039/55/8071293 E-mail: tem@tem.it – Web site: http://www.tem.it VAT No./Taxpayer's Code 06464360483</p>
Machine name	FR.350 CRUSHER
Main standards of reference	<ul style="list-style-type: none"> ••Machinery Directive 2006/42/EC ••EMC Directive 2014/30/EC ••Low Voltage Directive 2014/35/EU ••UNI EN ISO 12100
Service centre	At manufacturer's plant (sole service centre)
Manual	March 2016
Revision	Rev.1

Table 1 – References

1.6 Glossary

Hazard/Danger: A potential source of injury or one which may be harmful to health;

Risk: A combination of the probability and the seriousness of an injury or harmful event, which may arise in a hazardous situation;

Danger zones: Any zone inside and/or near the machine where the presence of a person exposed constitutes a risk for the health and safety of the same person.

Exposed person: Any person who has their body or any part of their body in a danger zone.

Operator or machine operator: The person or persons with the job of installing, running, adjusting, servicing, cleaning, repairing and moving or doing maintenance on the machine.

Expert operator or qualified technician: Technician specifically authorised by the “Plant Manager” to set up and start, lubricate, grease, do routine and extraordinary maintenance on the machine.

Expert operator or qualified electrician: Technician specifically authorised by the “Plant Safety Manager” to set up and start, and do maintenance on the electrical parts of the machine.

Protective system: A device that reduces risk, on its own or with a protective cover.

Intended use: Use of the machine in compliance with the information in the instructions;

Reasonably predictable improper use: Any other use of the machine that is not specified in the instructions, but which may derive from easily predictable human behaviour.

2.0 SAFETY

2.1 Intended use

The intended use of the machine in compliance with the information in the instructions;

Only professional operators who have been trained to use the machine and who have read this manual must be allowed to use the machine.

Operators authorised to use the machine prepare the machine for service, start the machine and control and adjust the work parameters. All the operations must be performed in accordance with the operating commands and procedures described in the instruction manual.

The machine was designed to extract olive oil, and separate and drain process waste.

2.2 Reasonably predictable improper use

Reasonably predictable improper use is considered any other use of the machine that is not specified in the instructions, but which may derive from easily predictable human behaviour.

On the basis of the manufacturer's experience, the machine should not be used in the following cases of improper use.

The manufacturer declines any responsibility in the case of improper use of the machine for which it was not designed and built.

The safety regulations and instructions in this manual must always be scrupulously observed. In particular, the operating limits specified in the manual must be observed. Unauthorised personnel must not be allowed near the equipment while it is being used.

Only suitably trained operators equipped with their own personal protective equipment should be allowed to use, service and repair the machine.

The manufacturer shall also be relieved of liability in the following cases:

- Incorrect installation;
- Improper machine/plant use;
- Tampering;
- Tampering with or bypassing the protective systems, also temporarily.
- Unauthorised modifications;
- The use of non-original spare parts;
- Non-compliance with the instructions provided;
- Non-observance of the maintenance schedule;
- Exceptional events;
- Use by operators who have not reached the minimum age required by the laws in force for work in the respective countries the machine is used in.
- Use by operators who have not been previously trained and informed of every risk and the residual machine risks as well as safety.
- Not using the Personal Protective Equipment (PPE) required by the instructions and the rules and regulations in force in the country the machine is used in.
- Using the machine also when it shows signs of malfunctioning or is partially faulty.

- Using the machine in a way which is not compliant with its limits of use (materials, speed, etc.).
- The simultaneous use of the machine by two or more operators who could put each other in danger, or put other exposed persons in danger.
- If used by the machine operator who fails to check that there are no exposed persons in the danger zones of the machine before using the controls.

Using the machine is forbidden:

- In places open to the public;
- In places where there is a risk of explosion and/or fire;
- In places contaminated by agents such as dust, acids, corrosive gasses, etc.;
- In places where there is the possibility of exposing it to radiation.

The work area must be cleaned with the machine stopped and with the electrical power switched off.

In normal conditions of use, removing the safety systems or protective covers is strictly prohibited.

2.3 User's responsibility

The Company using the machine must check that the operators doing the various jobs:

- have read and understood the use and maintenance instructions;
- are suitably trained for the jobs to be done, so they can do the same safely;
- have received specific training on how to use the machine properly;
- have been equipped with suitable personal protective equipment;
- are in a fit physical and mental condition (not under the effect of alcohol, medication or drugs).

2.4 Specific safety instructions

- The Machine must not be used for any other use except for that described in paragraph 3.2;
- Do not remove any safety system and do not attempt to deactivate or bypass the preventive and safety function of the same;
- Do not use any mechanical element to deactivate any kind of interlocking protective system;
- Always keep the machine serviced and in an efficient working condition;
- Regularly check (at least once a year) that none of the bolts on the load-bearing structures, covers, doors or motor connections have worked loose;
- Do not hold cloths, pieces of fabric or anything else near rotating parts of the machine.
- Only wash the machine with non-toxic products suitable for foodstuffs;
- Before doing any maintenance or removing the protective guards, it is obligatory to:
- Turn the electrical power off by opening the power line circuit breakers of both the main power board and the auxiliary power board, locking them with a padlock and giving the key of the padlock to the technicians doing the repairs;
- Check the mushroom-shaped emergency stop buttons have been pressed and locked;

- Place a sign on the power board warning “Machine being serviced”.
- Before starting the machine, check the electrical power line is protected by equipotential protection circuit breakers and the section and insulation of the conductors is that required by regulations;
- All the personnel who will use, service and install the machine must know the safety regulations and be in perfect physical and mental conditions;
- Anyone who is not specifically authorised to use the machine must be prevented from gaining access to the same;
- If any unusual noise or anomalous operation is noticed when using the machine, stop all moving parts and check to see where the problem is coming from. In any case, to prevent damage if mistakes are made when checking or controlling the machine, contact MORI TEM for explanations.

2.5 Job qualifications

In accordance with the manufacturer's risk assessment, the following table sums up how personnel must be qualified for the jobs done on the machine. The qualifications: “machine OPERATOR”, “MAINTENANCE TECHNICIAN”, “SPECIALIZED TECHNICIAN” and “MANUFACTURER'S TECHNICIAN”, are used to provide a clearer interpretation of the term “OPERATOR” as defined by Machinery Directive 2006/42/EC.

JOB	ORDINARY PERSON	OPERATOR	MAINTENANCE TECHNICIAN	SPECIALIZED TECHNICIAN	MANUFACTURER'S TECHNICIAN
Pass nearby or stop near the machine	☑	☑	☑	☑	☑
Transporting, unloading and storage	⊖	⊖	⊖	☑ (1)	⊖
Installation and assembly	⊖	⊖	⊖	☑	☑
Putting the machine into service	⊖	⊖	⊖	☑	☑
Use	⊖	☑	☑	☑	☑
Non-specialized maintenance (cleaning, inspecting)	⊖	☑	☑	☑	☑
Specialized maintenance (adjustments and replacing parts)	⊖	⊖	☑	☑	☑
Fault-finding and repairs	⊖	⊖	☑	☑	☑
Dismantling and scraping	⊖	⊖	⊖	☑ (2)	⊖
	A	B		C	
PERSONNEL TRAINING LEVEL					
A) UNTRAINED PERSONNEL B) TRAINED C) TRAINED (EXPERT TECHNICIAN)					

Key: ☑ Allowed ⊖ Not allowed

NOTE

(1): Technician specialized in moving loads.

(2): Technician specialized in waste disposal.

2.6 Workplaces

The work area must never be occupied in a way that interferes with the operator's free movement.

Operators must be able to gain immediate access to the machine in an emergency.

Access to the above area is forbidden for anyone who is not a machine operator, to prevent hazards caused by distraction or carelessness at work.

It is therefore recommended that the operator keeps the work area free of any tools and forbids any unauthorized access in order to work in safe operating conditions.

Workplace layout (OPERATOR)

Operators must only occupy the external areas of the machine shown in the following figure, and gain access to the zones protected by mobile protective covers to perform the operations described, using the appropriate openings left for this purpose.

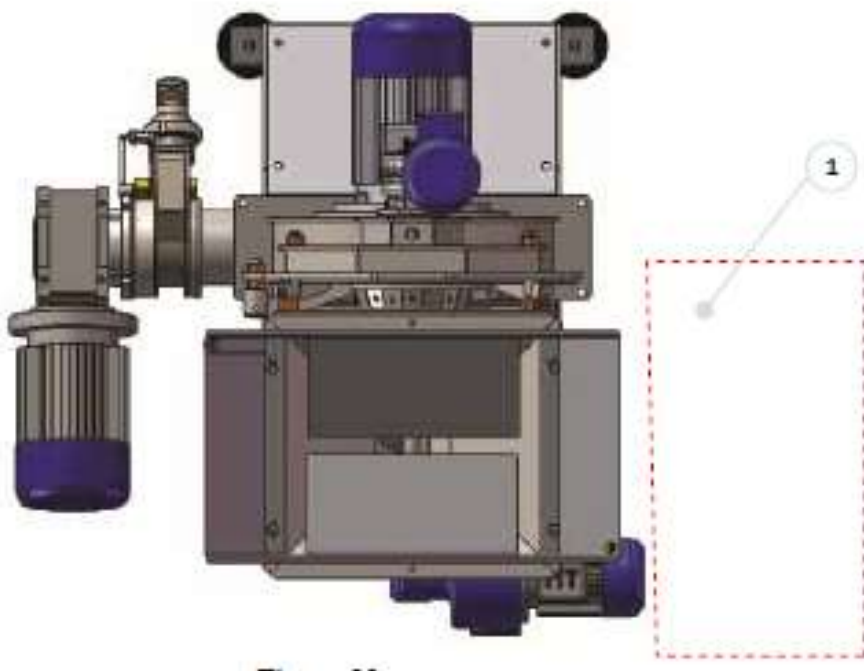

Ref.	Description of the work station
1	<p>OPERATOR STATION (MAIN CONTROL PANEL AND OLIVES' LOADING STATION)</p> <p>External area of the machine, from which the machine can be turned on, started, and the work parameters can be set. The operator stands in the zone for the time required to start the machine, set the work parameters and supervise the machine.</p> <p>External area of the machine, from which olives can be loaded by hand into the hopper.</p>

Workplace layout (MAINTENANCE TECHNICIAN)

The maintenance technicians must perform the maintenance operations described in the areas of the machine shown in the following figure, and only gain access to the zones protected by fixed and mobile protective covers for the operations described after having disconnected the machine from all its energy sources and checked there is no residual energy accumulated anywhere in the machine (ex. charges in condensers, accumulated pressure, etc.).

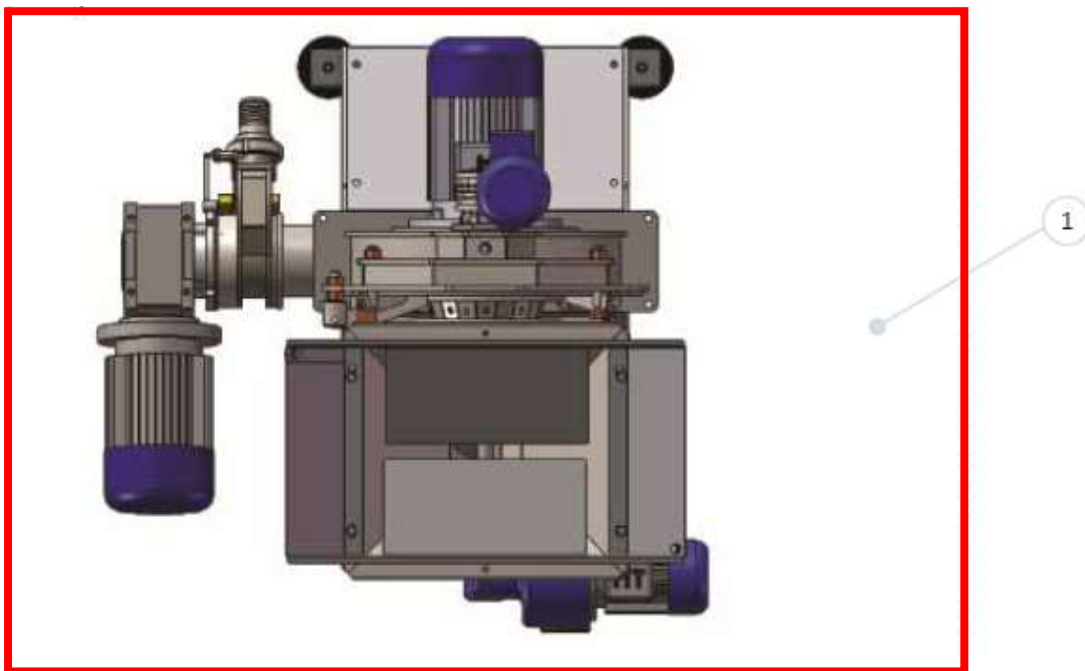

Ref.	Description of the work station
1	MACHINE External and internal area to which only specialized electrical and/or mechanical maintenance technicians can gain access.

2.7 Protective measures adopted

- This paragraph contains information on the protective measures adopted to eliminate or reduce the risks related to the machine.
-
- When a protective measure adopted does not completely eliminate a risk, but a lesser risk remains, this is described in the manual as a residual risk.

The protective measures adopted must be checked and effectively maintained during the entire working life of the machine.

- Perform the periodic checks described in the manual.
- It is forbidden to remove or even temporarily bypass the protective measures (ex. protective covers, photocell barriers, etc.).

Layout of protective measures adopted

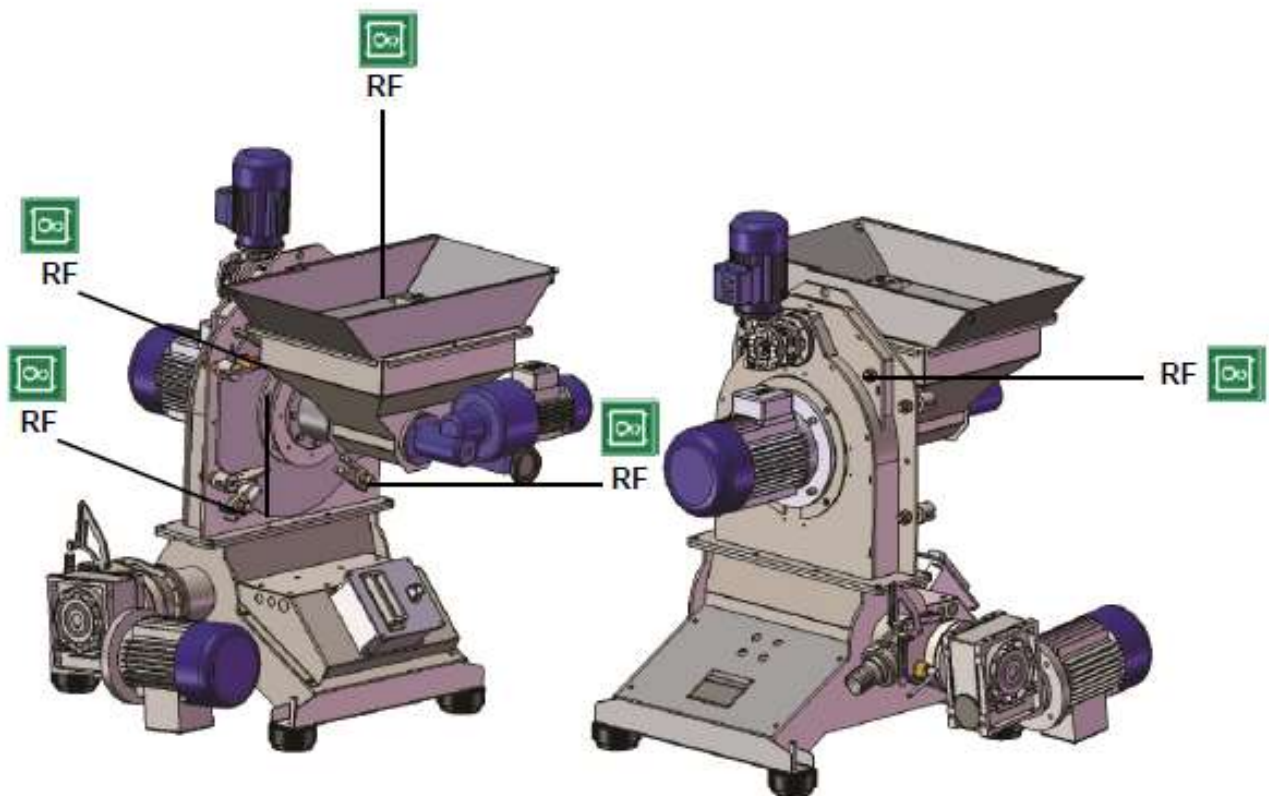

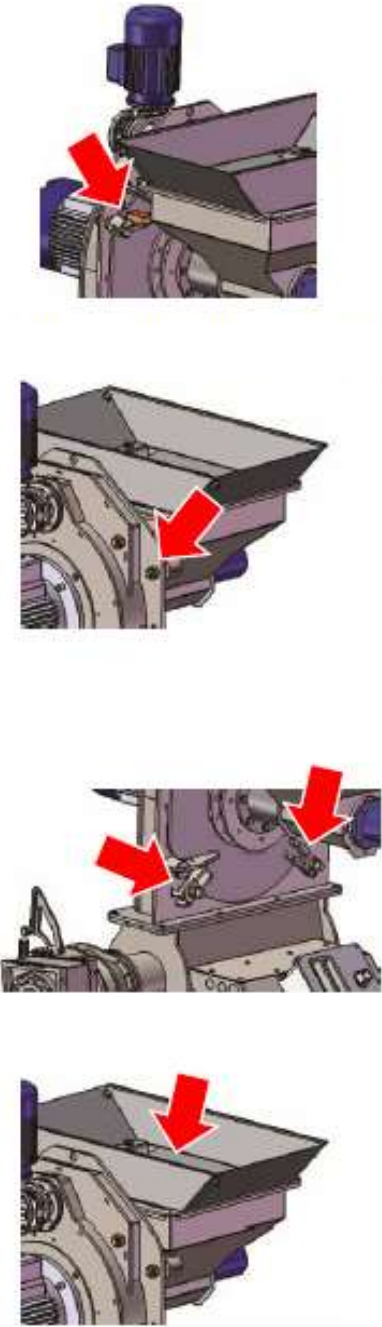

Table of protective measures

MEASURE	TYPE / Function	Photo / notes	CHECK
<p>RF</p> 	<p>FIXED PROTECTIVE COVER Protection over moving machine members consisting of fixed panels which can only be removed with tools (mesh and/or sheet steel).</p>	 <p>The 'Photo / notes' column contains four technical drawings of a machine, likely a lathe or similar industrial equipment. Each drawing highlights a different fixed protective cover with a red arrow. The covers are made of sheet steel and are designed to be removed with tools. The drawings show the covers from various angles, including top-down and side views, illustrating their placement and how they enclose moving parts of the machine.</p>	<p>ORE</p> <p>ORE B</p> <p>VE</p>



2.8 Checking the protective measures adopted

In accordance with paragraph 1.7.1 of European Directive 2006/42/EC, the following information and warnings are provided on the machine.



The non-observance of any instructions because a safety label has become illegible, been lost or is simply not observed, can cause serious accidents.





- It is obligatory to know and observe the information and warnings on the machine in compliance with the meaning and the actions described in this instruction manual.
- The information and warnings on the machine must be kept in a good condition for the entire operational life of the machine; for this purpose some specific instructions for performing checks are given in the following paragraphs.
- The manufacturer will not be held responsible under any circumstances for the non-observance of the instructions on the machine and in the manuals supplied with the same.



Summary table of information and warnings

Ref.	PICTOGRAM	INSTRUCTIONS / WARNINGS
SL01		<p>Maintain a safe distance to avoid dangerous direct or indirect contact with live parts. Observe safety regulations and use suitable Personal Protective Equipment (PPE) such as gloves offering protection against electric shocks.</p>
SL02		<p>Do NOT remove the protective covers protecting moving machine members. Only work on the machine with the protective covers removed if the machine has been disconnected from the electrical power line.</p>
SL03		<p>Beware of moving machine members when the machine is operating. Do NOT put your hands into the slots used to insert the product or near moving machine members.</p>









2.9 Protective measures that come under the user's responsibility









Symbol	Description	Technical standard
	<p>Full body protection (1, 2, 3, 4, 5 6, 7)</p>	<p>1) UNI EN ISO13688 Protective clothing. General requirements.</p>
	<p>Always wear suitable protective clothing for the job being done.</p> <p>The column on the right lists the standards of reference on the basis of the required protection.</p>	<p>2) UNI EN ISO 342 Garments and clothing combinations for protection against cold</p> <p>3) UNI EN ISO 11612 Garments that protect the body from heat and flame</p> <p>4) UNI EN 943-1-2 Protective clothing against chemicals</p> <p>5) UNI EN 13034 Protective clothing against liquid chemicals</p> <p>6) UNI EN 1149 Protective Clothing - Electrostatic Properties</p> <p>7) IEC EN 61482-1-2 Protective clothing against the thermal hazards of an electric arc</p>
	<p>Head protection</p>	<p>UNI EN 397 Industrial safety helmets</p>
	<p>Always wear a safety helmet when lifting and positioning the machine and in all cases when there is the risk of objects falling from a height.</p>	

Symbol	Description	Technical standard
	<p>Hand protection (1, 2, 3)</p>	<p>1) UNI EN 374 Protective gloves against chemicals and micro-organisms</p>
	<p>Always wear protective gloves whenever performing operations in which you could be exposed to risks. The column on the right lists the standards of reference on the basis of the required protection.</p>	<p>2) UNI EN 388 Gloves giving protection from mechanical and electrostatic risks</p> <p>3) UNI EN 407 Protective gloves against thermal risks</p>
	<p>Eye protection</p> <p>Always wear eye protection when performing operations in which there is the risk of materials being projected or exposure to splashes or jets of liquids.</p>	<p>UNI EN 166 Personal Eye-protection - Specifications</p>
	<p>Ear protection (1, 2)</p>	<p>1) UNI EN 352-1 Ear muffs</p>
	<p>Use personal protective equipment for the ears in accordance with the noise risk assessment in the workplace and the regulations in force in the country you are working in. The column on the right lists the standards of reference on the basis of the required protection.</p>	<p>2) UNI EN 352-2 Earplugs</p>
	<p>Foot protection (1, 2, 3)</p>	<p>1) UNI EN ISO 20345 Safety shoes</p>
	<p>Always wear safety footwear. The column on the right lists the standards of reference on the basis of the required protection.</p>	<p>2) UNI EN ISO 20346 Protective footwear</p> <p>3) UNI EN ISO 20347 Occupational footwear</p>

	<p>Respiratory protective devices (1, 2, 3, 4)</p> <hr/> <p>Always wear devices protecting the respiratory tract when cleaning the machine with solvents or chemical products.</p> <p>The column on the right lists the standards of reference on the basis of the required protection.</p>	<p>1) UNI EN 149 Filtering halfmasks to protect against particles</p> <p>2) UNI EN 405 Valved filtering half masks to protect against gases or gases and particles</p> <p>3) UNI EN 143 Particle filters</p> <p>4) UNI EN 14387 Gas filters and combined filters</p>
	<p>Protection against falls from a height (1, 2, 3, 4, 5, 6, 7, 8)</p> <hr/> <p>Always wear a safety body belt and harness when working at a height.</p> <p>The column on the right lists the standards of reference on the basis of the required protection.</p>	<p>1) UNI EN 353-1-2 Guided fall arrestors</p> <p>2) UNI EN 354 Lanyards</p> <p>3) UNI EN 355 Energy absorbers</p> <p>4) UNI EN 360 Guided type fall arresters including a flexible anchor line</p> <p>5) UNI EN 361 Full body harnesses</p> <p>6) UNI EN 363 Fall arrest systems</p> <p>7) UNI EN 795 Anchor devices</p>

2.10 Using PPE

Phase								
Operation								
Transportation								
Moving and transporting the machine	X (1)	X	X (2)			X (1)		
Assembling, installing and putting the machine into service								
Assembly/disassembly	X (1)		X (2)			X (1)		
Adjustments								
Washing the machine for the first time	X (1)		X (1)	X		X (1)		
Positioning the machine	X (1)		X (2)			X (1)		
Adjusting the nozzles	X (1)		X (2)			X (1)		
Use								
Starting the work cycle	X (1)		X (2)			X (1)		
Stopping the work cycle	X (1)		X (2)			X (1)		
Emergency stop	X (1)		X (2)			X (1)		
Normal operation	X (1)		X (2)			X (1)		
Using the controls	X (1)		X (2)			X (1)		
Loading the hopper	X (1)		X (2)			X (1)		
Oil, paste drain	X (1)		X (1)			X (1)		
Maintenance								
Various operations, inspections, cleaning, etc.	X (1)		X (2)	X		X (1)		
Working at a height	X (1)		X (2)			X (1)		X (5)
Lubricating/greasing	X (1)		X (1)	X		X (1)	X (1)	
Working on the electrical system	X (1)		X (2)			X (1)		
Working on the air system	X (1)		X (2)	X		X (1)		
Removing toxic/noxious substances after an accidental spillage	X (1)		X (1)	X		X (1)	X (1)	
Replacing worn parts and adjusting components	X (1)		X (2)			X (1)		

Phase								
Operation								
Changing and/or unblocking a jammed decanter drive belt.	X (1)		X (2)			X (1)		
Replacing the water heating elements	X (1)		X (2) X (3)			X (1)		
Washing the machine	X (1)		X (1)	X		X (1)		
Fault-finding/anomalies								
Removing blockages	X (1)		X (1)	X				
Faulty components	X (1)					X (1)		
Escape and rescue	X (1)		X (2)			X (1)		
Dismantling, scrapping, disposal								
Waste disposal when scrapping	X (1)		X (1) X (2)	X		X (1)		

2.11 Warnings on residual risks

In compliance with paragraph 1.7.2 of European Directive 2006/42/EC, the remaining residual risks are described despite the fact that protective measures have been included in the design phase and additional protective measures have been applied.

The following paragraphs describe the residual risks in terms of the working life of the machine:

N.B.: When assessing the risks, the manufacturer, in compliance with the laws in force, did not allow for (not had any information on) any risks related to the workplace and specific work procedures adopted by the user.

N.B.: These abbreviations are used in the risk sheets in the following paragraphs:

OrdP = Ordinary Person
 SpecT = Specialized Technician
 ManT = Manufacturer's Technician
 OP = Operator
 MA = Maintenance technician
 Danger zones

Ref.	Description	Note
Z00	All zones	The risk may be present in all zones.
Z02	Loading zone	Zone in which the loading operations are performed.
Z05	External area	The external area around the machine where the operator normally stands when operating it, and to do maintenance.

Zone layout



Figura 14



Any phase

Operation	Passing by or remaining near danger zones		
Person:	OrdP	Zones	Z00
Dangerous event	Various types of events depending on the work cycle of the machine and the work environment.		
Danger (Origin - Consequence)	Sources of danger on the machine or parts of the same.		
	Hazards deriving from the effects produced by sources of danger on the machine or parts of the same.		
ATTENTION	Residual risk		
	Ordinary persons who have not been trained may be exposed to various risks deriving both from the machine and the work environment.		
	Instructions		
	Ordinary persons who for whatever reason pass by or remain near machinery must always be accompanied by a trained person informed of the relevant risks, whose duty is to supervise ordinary persons. The employer must limit access for ordinary persons to danger zones using suitable company procedures.		

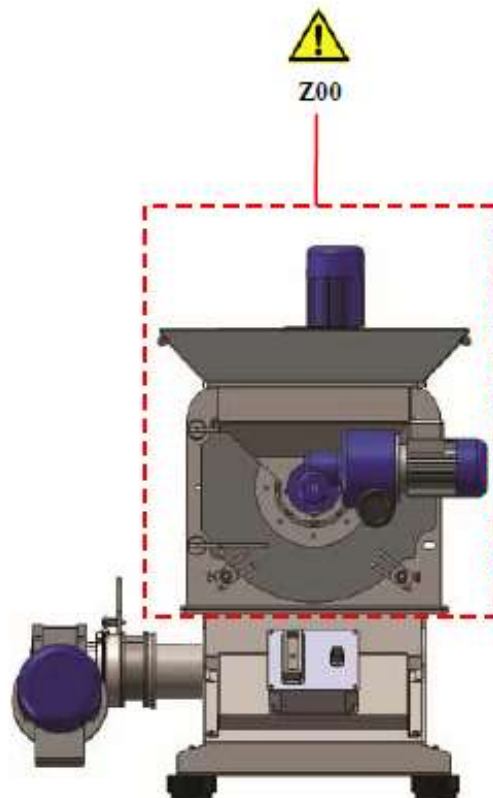
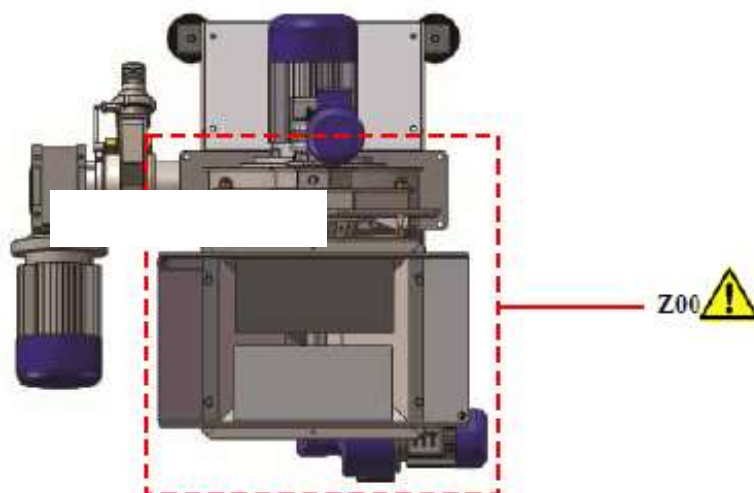
Transportation

Operation	Moving and transporting the machine		
Person:	SpecT	Zones	Z00
Dangerous event	Contact with sharp parts that could cut, sharp corners and edges of the machine.		
Danger (Origin - Consequence)	Sharp parts that could cut		
	Cutting of hands or arm		
ATTENTION	Residual risk		
	Exposure of maintenance technician and specialised technician to mechanical risks during transportation, assembly or disassembly.		
	Instructions		
	<ul style="list-style-type: none"> - The operation must only be performed by an expert person with the relevant know-how and experience, so they are able to analyse the risks and avoid the hazards that the job may entail. - Delimit the area of operations and forbid access to any unauthorised persons. - Follow the instructions for the operation to perform. - The employer should only use an expert person for the transportation, assembly or disassembly operations. - Do not perform any maintenance operations that are not described in the instructions supplied or operations which might require specific knowledge and the manufacturer's assistance. 		
	PPE		
	See chapter on "Safety", paragraph "Protective measures that come under the user's responsibility"		

Operation	Moving and transporting the machine		
Person:	SpecT	Zones	Z00
Dangerous event	Contact with sharp parts that could cut, sharp corners and edges of the machine.		
Danger (Origin - Consequence)	Sharp parts that could cut		
	Cutting of hands or arm		
ATTENTION	Residual risk		
	Exposure of maintenance technician and specialised technician to mechanical risks during transportation, assembly or disassembly.		
	Instructions		
	<ul style="list-style-type: none"> - The operation must only be performed by an expert person with the relevant know-how and experience, so they are able to analyse the risks and avoid the hazards that the job may entail. - Delimit the area of operations and forbid access to any unauthorised persons. - Follow the instructions for the operation to perform. - The employer should only use an expert person for the transportation, assembly or disassembly operations. - Do not perform any maintenance operations that are not described in the instructions supplied or operations which might require specific knowledge and the manufacturer's assistance. 		
	PPE		
	See chapter on "Safety", paragraph "Protective measures that come under the user's responsibility"		

Operation	Moving and transporting the machine		
Person:	SpecT	Zones	Z00
Dangerous event	Any falling load when moving also after a cable used to lift the load breaks.		
Danger (Origin - Consequence)	Falling objects		
	Crushing of body and head		
WARNING	Residual risk		
	The person moving and transporting the load may be exposed to the risk of moving parts falling.		
	Instructions		
	<ul style="list-style-type: none"> - The operation must only be performed by an expert person (EXP) with the relevant know-how and experience, so they are able to analyse the risks and avoid the hazards that the job may entail. - Delimit the area of operations and forbid access to any unauthorised persons. - Follow the instructions provided for lifting and moving the load. - The employer should only use an expert person for moving and transporting operations. 		
	PPE		
See chapter on “Safety”, paragraph “Protective measures that come under the user's responsibility”			

Assembling, installing and putting the machine into service

Operation	Assembly		
Person:	SpecT MA	Zones	Z00
Dangerous event	Contact with sharp elements or edges of the machine		
Danger (Origin - Consequence)	Sharp parts that could cut		
	Cutting of hands or arm		
ATTENTION	Residual risk		
	Exposure of maintenance technician and specialised technician to mechanical risks during transportation, assembly or disassembly.		
	Instructions		
	<ul style="list-style-type: none"> - The operation must only be performed by an expert person with the relevant know-how and experience, so they are able to analyse the risks and avoid the hazards that the job may entail. - Delimit the area of operations and forbid access to any unauthorised persons. - Follow the instructions for the operation to perform. - The employer should only use an expert person for the transportation, assembly or disassembly operations. - Do not perform any maintenance operations that are not described in the instructions supplied or operations which might require specific knowledge and the manufacturer's assistance. 		
	PPE		
	See chapter on "Safety", paragraph "Protective measures that come under the user's responsibility"		

Operation	Assembly		
Person:	SpecT ManT	Zones	Z05
Dangerous event	Direct or indirect contact with live parts		
Danger (Origin - Consequence)	- Contact with live parts (direct contact) - Contact with elements that may become live in the case of a fault (indirect contact)		
	Electrocution		
WARNING	Residual risk		
	Risk of electrocution due to direct or indirect contact with live parts.		
	Instructions		
	- Operations performed on electrical equipment both when live or when the power has been disconnected must only be performed by expert persons (EXP) and warned persons (WAP), in accordance with the definition in IEC 11-27. Standard IEC EN 60204-1 makes no distinction between work done on electrical equipment with the power disconnected or live, and therefore does not require a Person qualified for electrical work (PQUAL) to perform this work, in accordance with the definition of IEC 11-27.		
	- Work done on live parts inside the electrical board must only be performed after having disconnected the power and opened the door of the board, then reconnecting the power supplied to the equipment again by voluntarily turning the main switch ON.		
	PPE		
See chapter on “Safety”, paragraph “Protective measures that come under the user's responsibility”			

Operation	Assembly		
Person:	SpecT ManT	Zones	Z05
Dangerous event	Fire caused by electrical components and subsequent contact with flammable material		
Danger (Origin - Consequence)	Fire		
	Burning Burn		
WARNING	Residual risk		
	Risk of fire due to possible anomalies in the electrical system and subsequent contact with flammable material		
	Instructions		
	- The employer must provide fire-fighting equipment near the electrical boards		
	PPE		
See chapter on “Safety”, paragraph “Protective measures that come under the user's responsibility”			

Operation	Assembly		
Person:	SpecT MA	Zones	Z05
Dangerous event	Any falling load when assembling also after a cable used to lift the load breaks.		
Danger (Origin - Consequence)	Fall from a height Position high off the ground		
	Crushing of body and head		
WARNING	Residual risk		
	Exposure of maintenance technician and specialised technician to mechanical risks during transportation, assembly or disassembly.		
	Instructions		
	<ul style="list-style-type: none"> - The operation must only be performed by an expert person with the relevant know-how and experience, so they are able to analyse the risks and avoid the hazards that the job may entail. - Delimit the area of operations and forbid access to any unauthorised persons. - Follow the instructions for the operation to perform. - The employer should only use an expert person for the transportation, assembly or disassembly operations. - Do not perform any maintenance operations that are not described in the instructions supplied or operations which might require specific knowledge and the manufacturer's assistance. 		
	PPE		
See chapter on "Safety", paragraph "Protective measures that come under the user's responsibility"			

Operation	Assembly		
Person:	SpecT MA	- Zones	Z05
Dangerous event	Wrong connections and/or section of the power cable and protective systems		
Danger (Origin - Consequence)	Electrocution		
	Contact with elements that may become live in the case of a fault (indirect contact)		
WARNING	Residual risk		
	Risk of electrocution caused by wrong connections made between the machine and the electrical power line.		
	Instructions		
	<ul style="list-style-type: none"> - The machine is usually shipped with the power cable connected, the section of which has been calculated on the basis of the length of the cable. When possible the cable is supplied with an industrial type socket (single phase and/or 3-phase). - If the cable isn't long enough to install the machine in the workplace, the final customer must replace the cable with one of a suitable length and section. - The machine must be connected to a power point with overcurrent cutouts on the power line, which will be installed by the user. - The machine is designed to be used in a "damp environment" and therefore all the connections must be made guaranteeing a minimum degree of protection of IP 55. - Follow the assembly instructions in the manufacturer's use and maintenance manual and the wiring diagrams. 		
	PPE		
	See chapter on "Safety", paragraph "Protective measures that come under the user's responsibility"		

Operation	Assembly		
Person:	SpecT MA	- Zones	Z05
Dangerous event	Wrong connections and/or section of the equipotential protection cable		
Danger (Origin - Consequence)	Electrocution		
	Contact with elements that may become live in the case of a fault (indirect contact)		
WARNING	Residual risk		
	Risk of electrocution caused by wrong connection of the machine to the earthing system.		
	Instructions		
	<ul style="list-style-type: none"> - The machine must be connected to the earthing system using the PE equipotential protection terminal in the electrical board, using an earth conductor of a suitable length and section, which must be installed by the user. - Follow the assembly instructions in the manufacturer's use and maintenance manual and the wiring diagrams. 		
	PPE		
See chapter on "Safety", paragraph "Protective measures that come under the user's responsibility"			

Adjustments

Operation	Washing the machine for the first time		
Person:	OP MA	Zones	Z02
Dangerous event	Failure to wash the machine for the first time (sanitization)		
Danger (Origin - Consequence)	Biological or microbiological agents (viruses or bacteria).		
	Poisoning, sensitization		
WARNING	Residual risk		
	Risk of contaminating foodstuffs if the machine isn't cleaned properly		
	Instructions		
	<ul style="list-style-type: none"> - It is obligatory to thoroughly clean the zone where the processed product will pass before putting the machine into service for the first time to remove any residues left from construction and protective substances used during transportation. - The machine has a washing circuit used to clean it, so the stone extractor/crusher, malaxer, decanter and pulper can be washed in sequence. - It is in any case necessary to thoroughly clean the machine, totally or partially dismantling parts of the same. Cleaning, while not strictly necessary for the machine to work, is essential to guarantee the quality of the processed product. - When cleaning, use a hose with a nozzle on the end to create a jet/spray of water under pressure. 		
	PPE		
	See chapter on "Safety", paragraph "Protective measures that come under the user's responsibility"		

Operation	Washing the machine for the first time		
Person:	OP MA	Zones	Z05
Dangerous event	Deriving from the type of substances used to clean the machine both due to the risk of contact with the skin and breathing in hazardous fumes (ex. accidentally inhaling or touching detergent mixes).		
Danger (Origin - Consequence)	Fluids		
	Poisoning, sensitization		
ATTENTION	Residual risk		
	The risk of sensitization deriving from the type of substances used to clean or lubricate the machine both due to the risk of contact with the skin and breathing in hazardous fumes (ex. accidentally inhaling or touching detergent mixes).		
	Instructions		
	Follow the instructions on the safety sheet of the product being used. The customer/employer must provide suitable PPE for the persons doing the cleaning or lubricating on the basis of the risks deriving from the use of any noxious substances.		
	PPE		
See chapter on “Safety”, paragraph “Protective measures that come under the user's responsibility”			

Operation	Washing the machine for the first time		
Person:	OP MA	Zones	Z0
Dangerous event	Deriving from the type of substances used to clean the machine both due to the risk of contact with the skin and breathing in hazardous fumes (ex. accidentally inhaling or touching detergent mixes).		
Danger (Origin - Consequence)	Fluids		
	Poisoning, sensitization		
ATTENTION	Residual risk		
	The risk of sensitization deriving from the type of substances used to clean or lubricate the machine both due to the risk of contact with the skin and breathing in hazardous fumes (ex. accidentally inhaling or touching detergent mixes).		
	Instructions		
	Follow the instructions on the safety sheet of the product being used. The customer/employer must provide suitable PPE for the persons doing the cleaning or lubricating on the basis of the risks deriving from the use of any noxious substances.		
	PPE		
See chapter on “Safety”, paragraph “Protective measures that come under the user's responsibility”			

Operation	Positioning the machine		
Person:	OP MA	Zones	Z05
Dangerous event	People getting hit by the moving machine and/or getting crushed between the machine and parts of the building (walls, columns, etc.) or other heavy equipment in the place where the machine will be installed.		
Danger (Origin - Consequence)	- Instability - Machine mobility		
	- Crushing - Getting hit		
ATTENTION	Residual risk		
	Risk of getting hit and crushed by the machine while it is moving		
	Instructions		
	- When moving the machine, always check there is no one in the zone in which the operation will be performed. Once the machine is in position, lock all four wheels with the brakes to make sure the machine remains stable while it is being used. - Always disconnect the electrical power cable to move the machine.		
	PPE		
	See chapter on “Safety”, paragraph “Protective measures that come under the user's responsibility”		

Use

Operation	Normal operation (operating the machine)		
Person:	OP	Zones	Z00 Z05
Dangerous event	Aerosol, spray of water and microscopic drops of oil produced during the work process.		
Danger (Origin - Consequence)	Aerosol		
	- Difficulty in breathing - Sensitisation		
ATTENTION	Residual risk		
	Various risks deriving from materials and substances (mixed oil/water aerosol)		
	Instructions		
	- Use the machine in an environment where there is suitable ventilation that will decrease the presence of an aerosol of water and microscopic oil drops in the air. - Do not use the machine in closed, non-ventilated environments.		
	PPE		
See chapter on "Safety", paragraph "Protective measures that come under the user's responsibility"			

Operation	Normal operation (operating the machine)		
Person:	OP	Zones	Z00 Z05
Dangerous event	Aerosol, spray of water and microscopic drops of oil produced during the work process.		
Danger (Origin - Consequence)	Aerosol		
	<ul style="list-style-type: none"> - Difficulty in breathing - Sensitisation 		
ATTENTION	Residual risk		
	Various risks deriving from materials and substances (mixed oil/water aerosol)		
	Instructions		
	<ul style="list-style-type: none"> - Use the machine in an environment where there is suitable ventilation that will decrease the presence of an aerosol of water and microscopic oil drops in the air. - Do not use the machine in closed, non-ventilated environments. 		
	PPE		
	See chapter on “Safety”, paragraph “Protective measures that come under the user's responsibility”		

Fault-finding/anomalies

Operation	Faulty components		
Person:	SpecT ManT	Zones	Z05
Dangerous event	Direct or indirect contact with live parts		
Danger (Origin - Consequence)	Contact with live parts Contact with elements that may become live in the case of a fault		
	Electrocution		
WARNING	Residual risk		
	Risk of electrocution due to direct or indirect contact with live parts.		
	Instructions		
	<p>- Operations performed on electrical equipment both when live or when the power has been disconnected must only be performed by expert persons (EXP) and warned persons (WAP), in accordance with the definition in IEC 11-27. Standard IEC EN 60204-1 makes no distinction between work done on electrical equipment with the power disconnected or live, and therefore does not require a Person qualified for electrical work (PQUAL) perform this work, in accordance with the definition of IEC 11-27.</p> <p>- Work done on live parts inside the electrical board must only be performed after having disconnected the power and opened the door of the board, then reconnecting the power supplied to the equipment again by voluntarily turning the main switch ON.</p>		
	PPE		
	See chapter on “Safety”, paragraph “Protective measures that come under the user's responsibility”		

Operation	Faulty components		
Person:	SpecT ManT	Zones	Z05
Dangerous event	Direct or indirect contact with live parts		
Danger (Origin - Consequence)	Contact with live parts Contact with elements that may become live in the case of a fault		
	Electrocution		
WARNING	Residual risk		
	Risk of electrocution due to direct or indirect contact with live parts.		
	Instructions		
	<p>- Operations performed on electrical equipment both when live or when the power has been disconnected must only be performed by expert persons (EXP) and warned persons (WAP), in accordance with the definition in IEC 11-27. Standard IEC EN 60204-1 makes no distinction between work done on electrical equipment with the power disconnected or live, and therefore does not require a Person qualified for electrical work (PQUAL) perform this work, in accordance with the definition of IEC 11-27.</p> <p>- Work done on live parts inside the electrical board must only be performed after having disconnected the power and opened the door of the board, then reconnecting the power supplied to the equipment again by voluntarily turning the main switch ON.</p>		
	PPE		
	See chapter on “Safety”, paragraph “Protective measures that come under the user's responsibility”		

Dismantling, scrapping, disposal

Operation	Disassembly		
Person:	SpecT ManT	Zones	Z05
Dangerous event	Direct or indirect contact with live parts		
Danger (Origin - Consequence)	Contact with live parts Contact with elements that may become live in the case of a fault		
	Electrocution		
WARNING	Residual risk		
	Risk of electrocution due to direct or indirect contact with live parts.		
	Instructions		
	<p>- Operations performed on electrical equipment both when live or when the power has been disconnected must only be performed by expert persons (EXP) and warned persons (WAP), in accordance with the definition in IEC 11-27. Standard IEC EN 60204-1 makes no distinction between work done on electrical equipment with the power disconnected or live, and therefore does not require a Person qualified for electrical work (PQUAL) perform this work, in accordance with the definition of IEC 11-27.</p> <p>- Work done on live parts inside the electrical board must only be performed after having disconnected the power and opened the door of the board, then reconnecting the power supplied to the equipment again by voluntarily turning the main switch ON.</p>		
	PPE		
See chapter on “Safety”, paragraph “Protective measures that come under the user's responsibility”			

Operation	Disassembly		
Person:	SpecT ManT	Zones	Z05
Dangerous event	Direct or indirect contact with live parts		
Danger (Origin - Consequence)	Contact with live parts Contact with elements that may become live in the case of a fault		
	Electrocution		
WARNING	Residual risk		
	Risk of electrocution due to direct or indirect contact with live parts.		
	Instructions		
	<p>- Operations performed on electrical equipment both when live or when the power has been disconnected must only be performed by expert persons (EXP) and warned persons (WAP), in accordance with the definition in IEC 11-27. Standard IEC EN 60204-1 makes no distinction between work done on electrical equipment with the power disconnected or live, and therefore does not require a Person qualified for electrical work (PQUAL) perform this work, in accordance with the definition of IEC 11-27.</p> <p>- Work done on live parts inside the electrical board must only be performed after having disconnected the power and opened the door of the board, then reconnecting the power supplied to the equipment again by voluntarily turning the main switch ON.</p>		
	PPE		
	See chapter on “Safety”, paragraph “Protective measures that come under the user's responsibility”		

Operation	Disassembly		
Person:	SpecT ManT	Zones	Z05
Dangerous event	Direct or indirect contact with live parts		
Danger (Origin - Consequence)	Contact with live parts Contact with elements that may become live in the case of a fault		
	Electrocution		
WARNING	Residual risk		
	Risk of electrocution due to direct or indirect contact with live parts.		
	Instructions		
	<p>- Operations performed on electrical equipment both when live or when the power has been disconnected must only be performed by expert persons (EXP) and warned persons (WAP), in accordance with the definition in IEC 11-27. Standard IEC EN 60204-1 makes no distinction between work done on electrical equipment with the power disconnected or live, and therefore does not require a Person qualified for electrical work (PQUAL) perform this work, in accordance with the definition of IEC 11-27.</p> <p>- Work done on live parts inside the electrical board must only be performed after having disconnected the power and opened the door of the board, then reconnecting the power supplied to the equipment again by voluntarily turning the main switch ON.</p>		
	PPE		
	See chapter on “Safety”, paragraph “Protective measures that come under the user's responsibility”		

3.0 PRESENTATION AND DESCRIPTION OF THE PLANT

3.1 Main parts of the plant

3.1.1 Nameplate

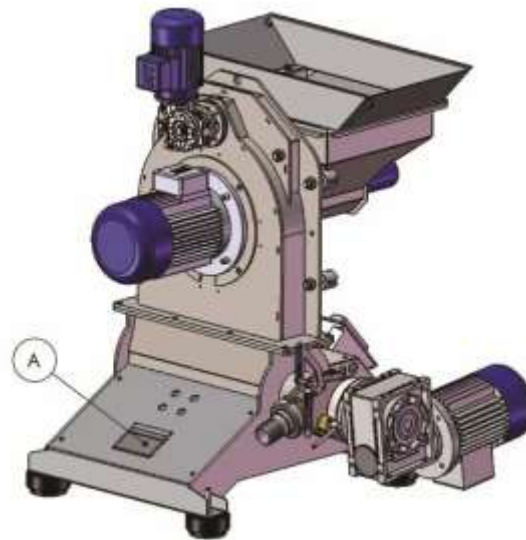

Figure 2

3.1.2 Overall dimensions

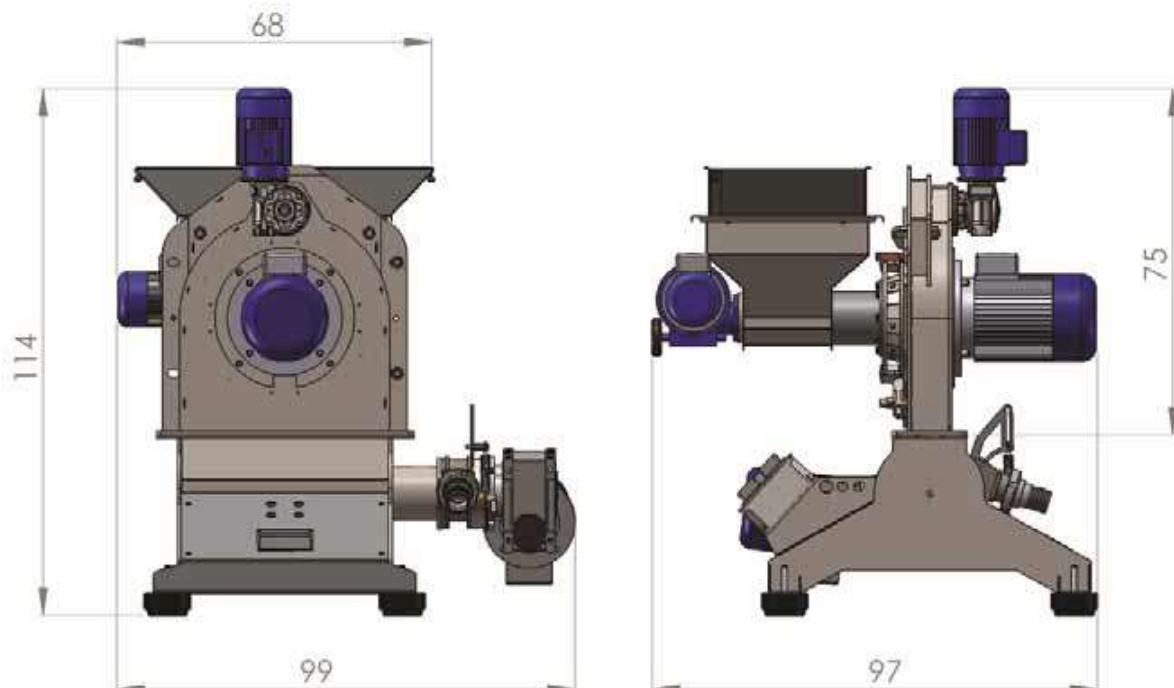

Figure 3

The crusher is equipped with a hopper receiving the olives and housing a screw driven by an adjustable speed motor for flow adjustment. Diameter of the screens of the crusher 350mm; crusher impeller with groove knives. The impeller can be foreseen with a pre-crusher to roughly crush the olives before being transferred to the blades. This is an unique system much appreciated by our customers all over the world. The cleaning of the crusher is carried out through a cleaning device positioned outside the screen. The speed of the crusher motor is, on demand (optional), controlled through an inverter positioned inside the control cabinet of the equipment. Positioned under the crusher, a dedicated pump with elliptical piston transfers the crushed paste on to the malaxers. All parts in contact are made of stainless steel AISI 304 and food grade material.

1. Feeding olives motor
2. Hopper overflow sensor connection
3. Hopper
4. Cleaner washing water inlet
5. Cleaner motor
6. Crusher motor
7. Electrical connection
8. Washing water discharge electrovalve
9. Washing water discharge
10. Washing water electrovalve
11. Washing water connection
12. Paste immission sensor
13. Paste immission

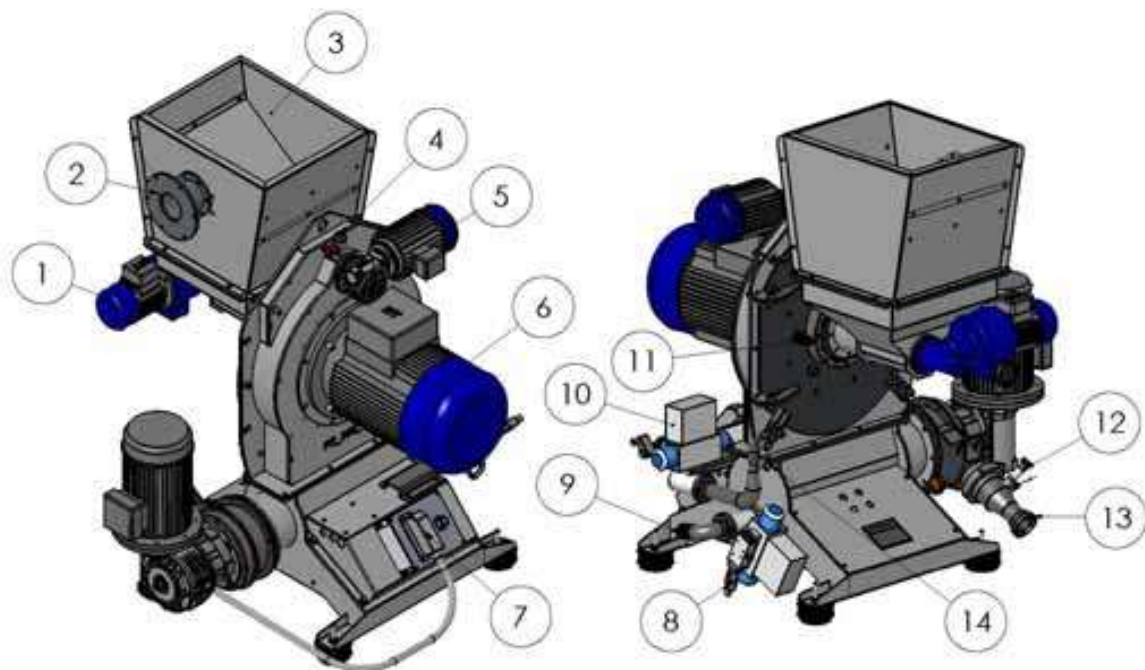

Figure 4

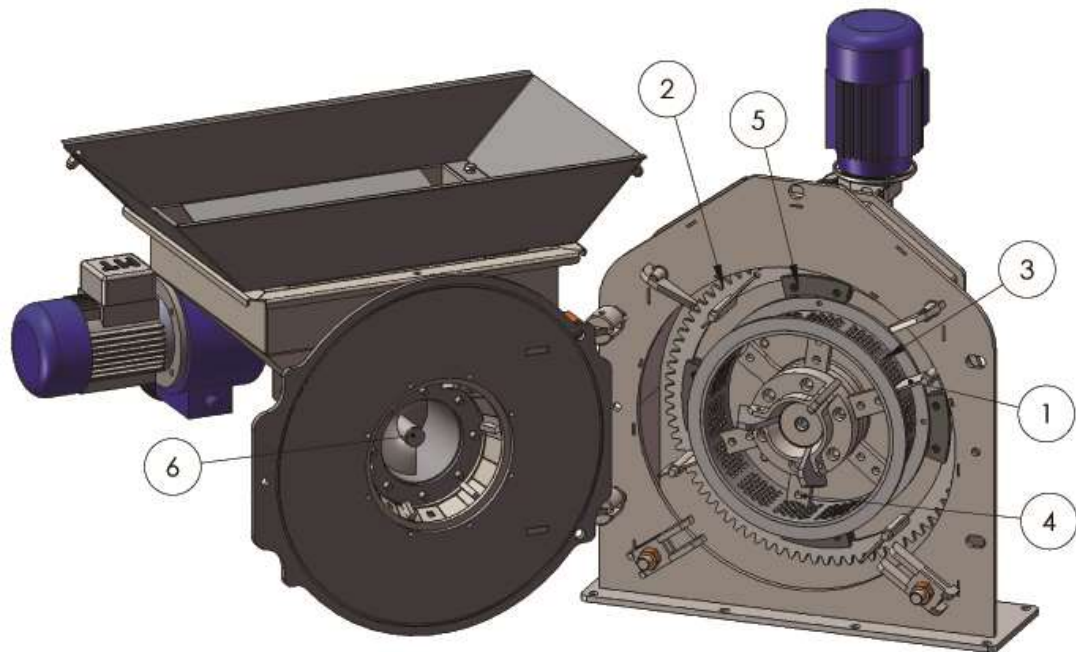

Figure 5

- 1 Cleaner blade (if fitted)
- 2 Cleaner crown (if fitted)
- 3 Crusher grating
- 4 Knife
- 5 Cleaner guide (if fitted)
- 6 Olive screw feeder

HOPPER OVERFLOW SYSTEM

The system stops the belt which carries the olives to the crusher when the hopper is full



Figure 6

EMERGENCY AND CLEANER WASHING VALVE (if present)

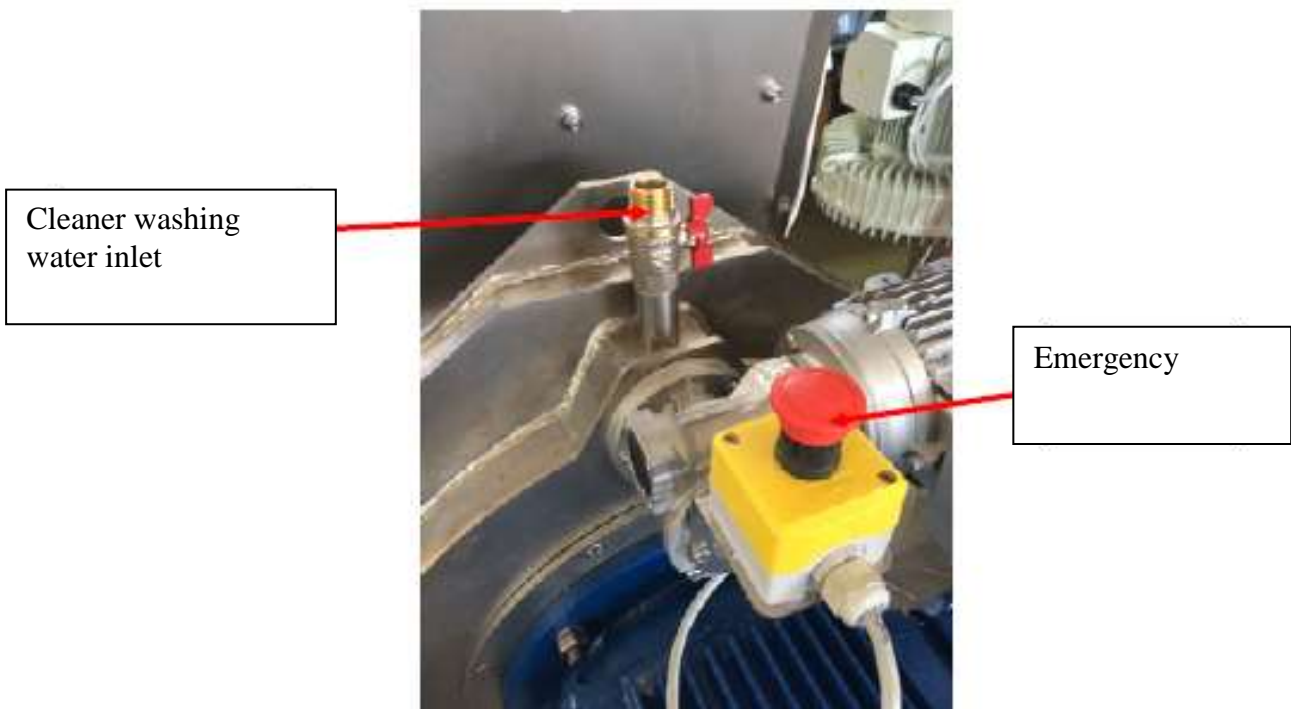

Figure 7

CRUSHER WASHING SYSTEM (if present)

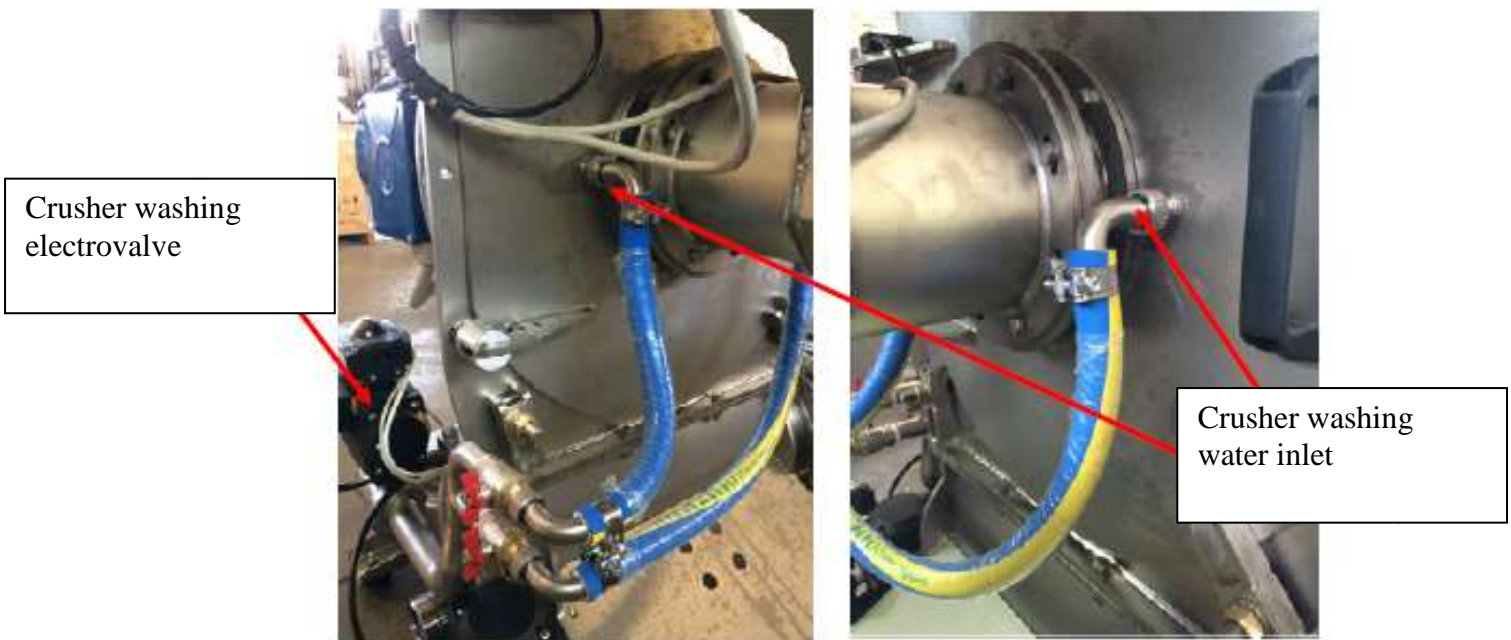

Figure 8

3.2 General safety regulations

3.2.1 *Illegal or improper use, or use which is not permitted*

The manufacturer declines any responsibility in the case of improper use of the machine for which it was not designed and built.

The safety regulations and instructions in this manual must always be scrupulously observed. In particular, the operating limits specified in the manual must be observed. Unauthorised personnel must not be allowed near the equipment while it is being used.

Only suitably trained operators equipped with their own personal protective equipment should be allowed to use, service and repair the machine.

The manufacturer shall also be relieved of liability in the following cases:

- incorrect installation;
- improper machine/plant use;
- tampering;
- unauthorised modifications;
- use of non-original spare parts;
- non-compliance with the instructions provided;
- non-observance of the maintenance schedule;
- exceptional events.

Using the machine is forbidden:

- in places open to the public;
- in places where there is a risk of explosion or fire;
- in places contaminated by agents such as dust, acids, corrosive gasses, etc.;
- in places where there is the possibility of exposing it to radiation.

The work area must be cleaned with the machine stopped and with the electrical power switched off.

In normal conditions of use, removing the safety systems or protective covers is strictly prohibited.

3.2.2 *User's responsibility*

The Company using the machine must check that the operators doing the various jobs:

- have read and understood the use and maintenance instructions;
- are suitably trained for the jobs to be done, so they can do the same safely;
- have received specific training on how to use the machine properly;
- have been equipped with suitable personal protective equipment;
- are in a fit physical and mental condition (not under the effect of alcohol, medication or drugs).

3.2.3 Specific safety instructions

- ⇒ The Machine must not be used for any other use except for that described in paragraph 3;
- ⇒ Do not remove any safety system and do not attempt to deactivate or bypass the preventive and safety functions of the same;
- ⇒ Do not use any mechanical element to deactivate any kind of interlocking protective system;
- ⇒ Always keep the machine serviced and in an efficient working condition;
- ⇒ Regularly check (at least once a year) that none of the bolts on the load-bearing structures, covers, doors or motor connections have worked loose;
- ⇒ Do not hold cloths, pieces of fabric or anything else near rotating parts of the machine.
- ⇒ Only wash the machine with non-toxic products suitable for foodstuffs;
- ⇒ Before doing any maintenance or removing the protective guards, it is obligatory to:
 - Turn the electrical power off by opening the power line circuit breakers of both the main power board and the auxiliary power boards, locking them with a padlock and giving the key of the padlock to the technicians doing the repairs;
 - Check the mushroom-shaped emergency stop buttons have been pressed and locked;
 - Place a sign on the power board warning “*Machine being serviced*”.
- ⇒ Before starting the machine, check the electrical power line is protected by equipotential protection circuit breakers and the section and insulation of the conductors is that required by regulations;
- ⇒ All the personnel who will use, service and install the machine must know the safety regulations and be in perfect physical and mental conditions;
- ⇒ Anyone who is not specifically authorised to use the machine must be prevented from gaining access to the same;
- ⇒ If any unusual noise or anomalous operation is noticed when using the machine, stop all moving parts and check to see where the problem is coming from. In any case, to prevent damage if mistakes are made when checking or controlling the machine, contact TEM for explanations.

4.0 INSTRUCTION MANUAL

4.1 Preparations for using the machine

4.1.1 Environmental operating conditions

The machine and the relevant electrical equipment have been designed and built to be installed in an industrial environment and only to be used in closed places where they are not subject to atmospheric agents.

Other temperatures may be permissible for short periods of time, but in any case not while the machine is running.

Other humidity levels may be permissible for short periods of time, but in any case not while the machine is running.

Other temperatures may be permissible if some parts of the machine are replaced.

Unless there are other contractual specifications to the contrary, it is understood that the machine can only operate in the following environmental conditions (Table 2). Other environmental conditions different to those specified can cause malfunctions or breakages and therefore dangerous situations for the health of the operator and exposed persons.



	ENVIRONMENT	CLOSED
	AMBIENT TEMPERATURE	> 5°C < 35°C
	PRODUCT TEMPERATURE	>10°C < 30°C
	MAXIMUM ALTITUDE	1,500 metres above sea level
	MAX. EXTERNAL HUMIDITY	50% R.H. at 40°C

Table 2 - Environmental operating conditions

Lighting and air conditioning

All the rooms where continuous work activities are performed must be sufficiently well lit by natural light so the stop buttons, emergency stop buttons, commands and controls are always well visible. If necessary, additional artificial lighting must be used. For this reason, the operators must be provided with portable lights to be used whenever necessary.

N.B. Do not connect the auxiliary lighting to the machine's electrical board.

In order to guarantee the best hygienic conditions, adequate ventilation must be provided for workers using suitable air-conditioning systems.

The temperature in the workplace must be suitable for the human body during working hours, allowing for the work methods and physical exertion required of the workers.

Noise

The noise emissions of the machine are within regulation limits.

Tests have been performed to measure the noise emissions in normal working conditions with the machine in automatic mode, in an industrial shed using class 1 (IEC 804) instrumentation, and the following sound pressure levels were measured (Table 3) with the readings taken from the

operator's station.

OPERATOR'S STATION	L_{pA} dB[A]
P1	85

Table 3 - Sound pressure level detected

- L_{pA} dB[A] = Average A-weighted sound pressure level emitted.
- P1 = Measurement taken in NOISIEST POSITION (which coincides with the operator's station when the machine must be monitored) of the ideal machine perimeter, at a distance of 1 metre from the machine and at a height of $1.55 \text{ m} \pm 0.075 \text{ m}$ from the floor.

The employer must observe acoustic criteria in regulations so the sound pressure level emitted by the machine does not exceed the acceptable level of 80 dB (Table 4) when it is installed in special conditions or if there have been changes in the environment.

L_{pA} dB[A]	ACTION
>80	Information provided to workers on the risks and preventive measures, as well as periodic inspections performed on their request.
>85	Preventive and periodic inspections, availability of PPE
>90	PPE obligatory, limited access

Table 4 - Sound pressure level limits and the relative measures

Risk of explosion or fire

As specified in the risk analysis, there is no risk of fire with this machine; however this risk must be considered in the analysis process on the basis of the environment and the regulations concerning said application. The machine has been designed and built to prevent any risk of fire or overheating caused by the machine itself and any risk of explosion; the machine must not in any case be used in zones where there is a risk of fire and/or explosions.

N.B. The machine has NOT been designed to be used in the presence of flammable liquids of any kind. The manufacturer is in no way responsible for any hazards which may derive from the above improper use of the machine.

4.2 Instructions

STARTING THE PLANT

Crushing phase

1. Turn the plant main switch “ON”
2. Check the emergency stop button is not pressed (it must be pulled out);
3. Press the START button
4. Turn the CRUSHER selector “ON”
5. Turn the CLEANER selector “ON”
6. Turn the OLIVES selector “ON”
7. Turn the PASTE PUMP selector “ON”
8. Put olives inside the hopper. The process starts.

SETTINGS

ADJUSTING THE OLIVES' FEED SPEED

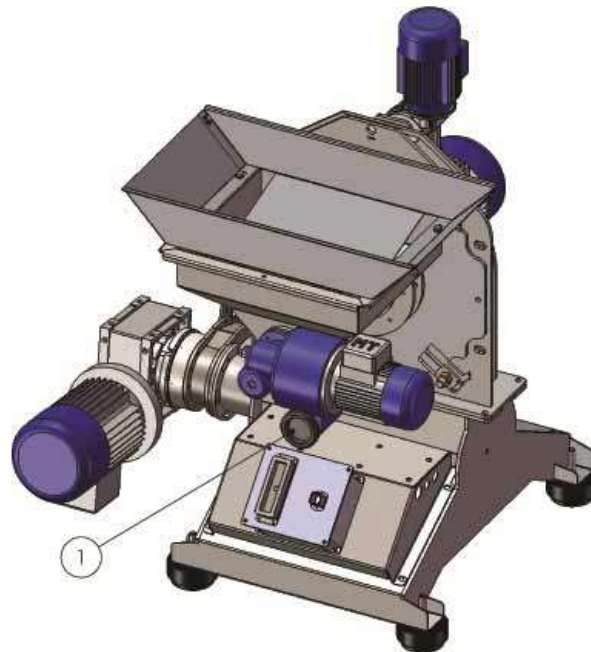

Figure 9

CLEANING



ATTENTION! The entire plant must be turned OFF and the power supplied to the board must be disconnected.

1. Open the crusher and clean inside by hand (Figure 10).

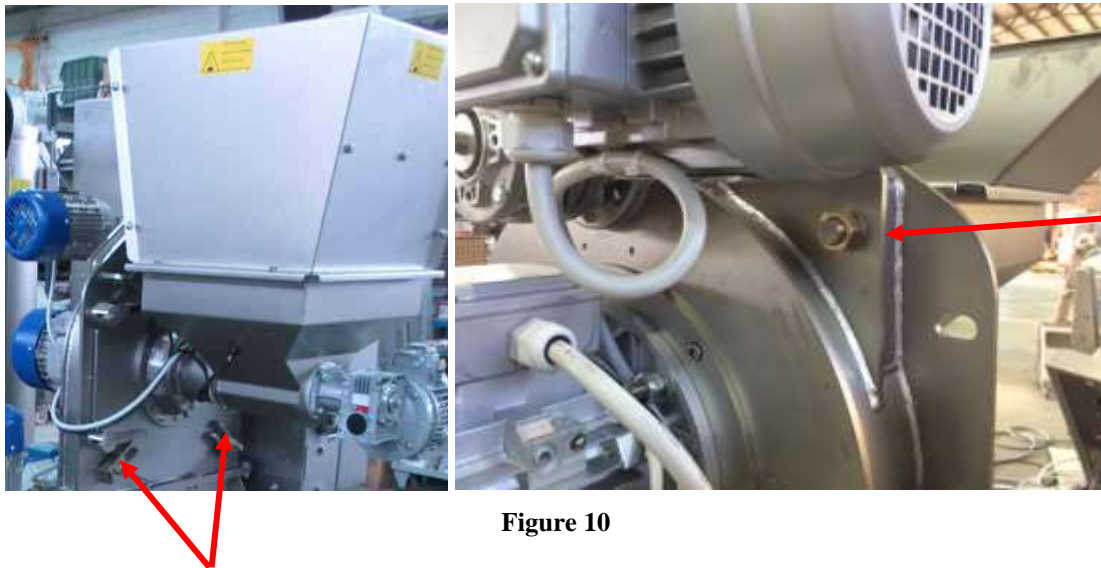

Figure 10

2. Wash inside the crusher, the impeller, the blades, the cleaner and grating, thoroughly. There must be no traces of paste inside.
3. Close the crusher completely.

MAINTENANCE

CRUSHER

Knives:

You should check the wear of the blades at the end of every processing season. If a lot of wear is noticed, unscrew the screws holding the knives and turn the knives around. If you notice a lot of wear also on this side of the knives the next time they are inspected, you will have to replace the knives. Make sure there are no chips, cracks or micro-cracking in the knives and that they are not so worn that the weight of the knife has been reduced considerably, as this could generate vibrations in the crusher. In this case, change the knife immediately.

Perforated grating:

Visual inspection. If you notice the grating is very worn you will have to replace it.