



SOLLEVATORE RIBALTATORE

ITA-ING



**MORI-TEM**

SOLLEVATORE RIBALTATORE

ITA Il sollevatore-ribaltatore di BINZ serve a svuotare le olive nella tramoggia dell'impianto. La cassa (BINZ) viene posizionata sul sollevatore-ribaltatore tramite un transpallet. La macchina è dotata di una centralina idraulica che aziona un pistone, il quale alza la cassa fino al completo svuotamento. Il sollevatore alza al massimo una cassa del peso complessivo di 500 Kg.

ENG The BINZ lifting/tipping unit is foreseen to blank the olives into the hopper of the olive oil extraction plant. The container (BINZ) is positioned onto the lifting/tipping unit by means of a transpallet. The unit is equipped with an hydraulic system operating a piston, which lifts the container till it is completely empty. Unit foreseen for lifting container/binz with maximum total weight of 500 kgs.

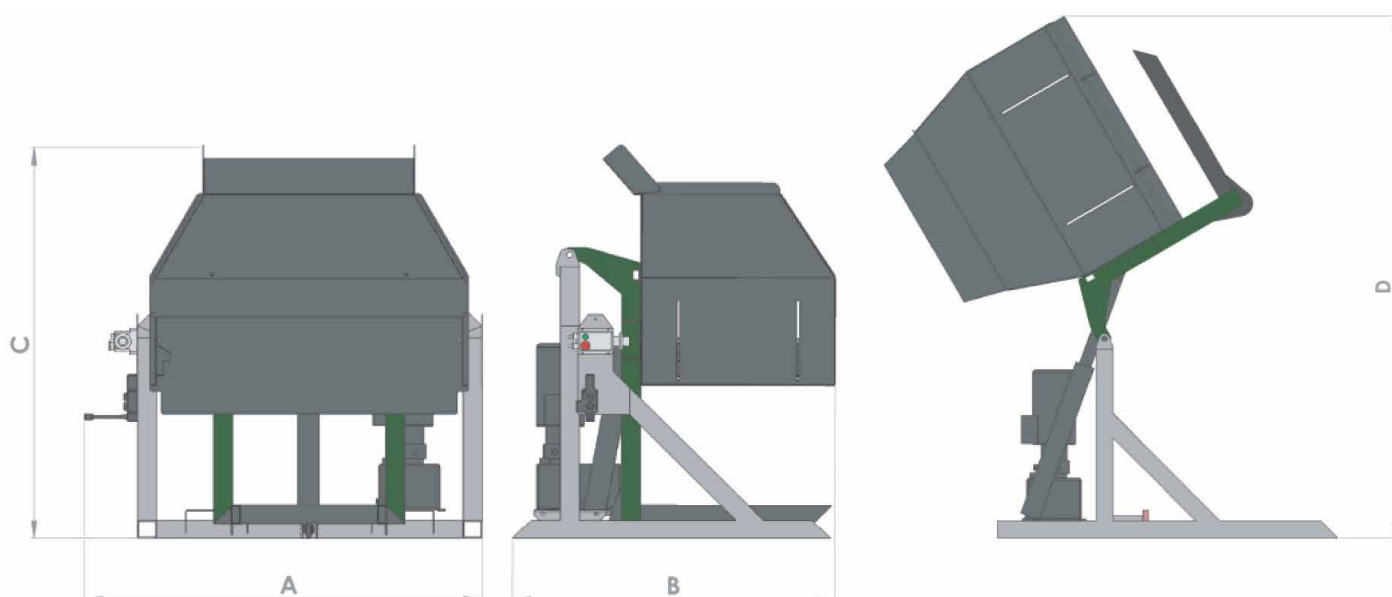

CARATTERISTICHE TECNICHE TECHNICAL FEATURES

| | POTENZA (kW) POWER REQUIREMENTS (kW) | DIMENSIONI (cm) DIMENSIONS (cm) | PESO (Kg) WEIGHT (Kg) |
|------|---|------------------------------------|--------------------------|
| SR.1 | 2 | A B C D 167 135 166 220 | 180 |