

HANSA C13

Operation, maintenance and safety manual



All operators must fully read and understand this operator's manual before using the chipper.

Keep this manual for future reference.



3 YEAR | **GLOBAL WARRANTY**

Register your Hansa chipper to qualify
www.hansaproducts.com/registration

TABLE OF CONTENTS

WHAT CAN MY HANSA CHIPPER PROCESS?	1
INTENDED USES OF THE CHIPPER	1
RECEIVING YOUR HANSA CHIPPER	1
CHIPPER COMPONENTS	1
ASSEMBLING THE CHIPPER	2
.....	3
.....	3
FIT THE FIXED OUTLETCHUTE	3
FIT THE SWIVEL OUTLETCHUTE	3
FIT THE INLET CHUTE	4
FIT THE DRAWBAR (OPTIONAL) PART	5
SAFETY	6
OPERATOR COMPETENCY	6
TOWING SAFETY (FOR ROADTOWABLE) MODEL	6
IDENTIFYING HAZARDS AND RISKS	7
OPERATION	8
SAFE SETUPPROCEDURE	8
SAFE OPERATINGPROCEDURE	8
STARTING PROCEDURE	10
SHUTDOWN PROCEDURE	11
PETROL.....	12
STORAGE	12
TROUBLESHOOTING	12
WHAT TO DO IF :	12
MAINTENANCE	13
KNIFE RE-SHARPENINGANDKNIFEREPLACEMENT	14
ANVIL ADJUSTMENTREPLACEMENT	17
ENGINE SERVICING	17
ENGINE OIL	17
BELT TENSION	18
BELT REPLACEMENT	19
TYRE PRESSURE	20
BOLT TORQUE	21
SPECIFICATIONS	21
SAFETY LABELS	22
SAFETY LABEL LOCATIONS	22
SAFETY LABEL EXPLANATIONS	22
HANSA GLOBAL INDUSTRIAL LIMITED WARRANTY	24
COMMISSIONING CHECKLIST AND REGISTRATION	26



www.theolivecentre.com
Code: CA3C13-P

What can my Hansa chipper process?

Intended uses of the chipper

The Hansa C13 chipper is built to process organic material including wooden branches not exceeding 90 mm in diameter. It is designed to be used on a regular basis to maintain large gardens, lifestyle blocks, acreages, along with use by semi commercial garden maintenance contactors and hire / rental companies. **Do NOT** use the chipper for any other purpose.

Organic wastes include:

- ✔ Prunings, stalks, roots, vegetable matter, hay, grass, bark
- ✔ Dry manure
- ✔ Branches
- ✔ Palm fronds
- ✔ Dead and hard timbers (Note: these will dull the knives faster)
- ✔ Paper or cardboard



Do NOT process:

- ✘ Flax, root balls
- ✘ Soil, bones, sand, grit, stones, metal

If you have any questions, contact your authorised dealer.

 **Do NOT** exceed 90 mm branch diameter

Receiving your Hansa chipper

You may receive your chipper assembled from your dealer or it may be packaged in two boxes. Assembly takes approximately 30

minutes, two people working together will make the assembly easier.

Chipper components

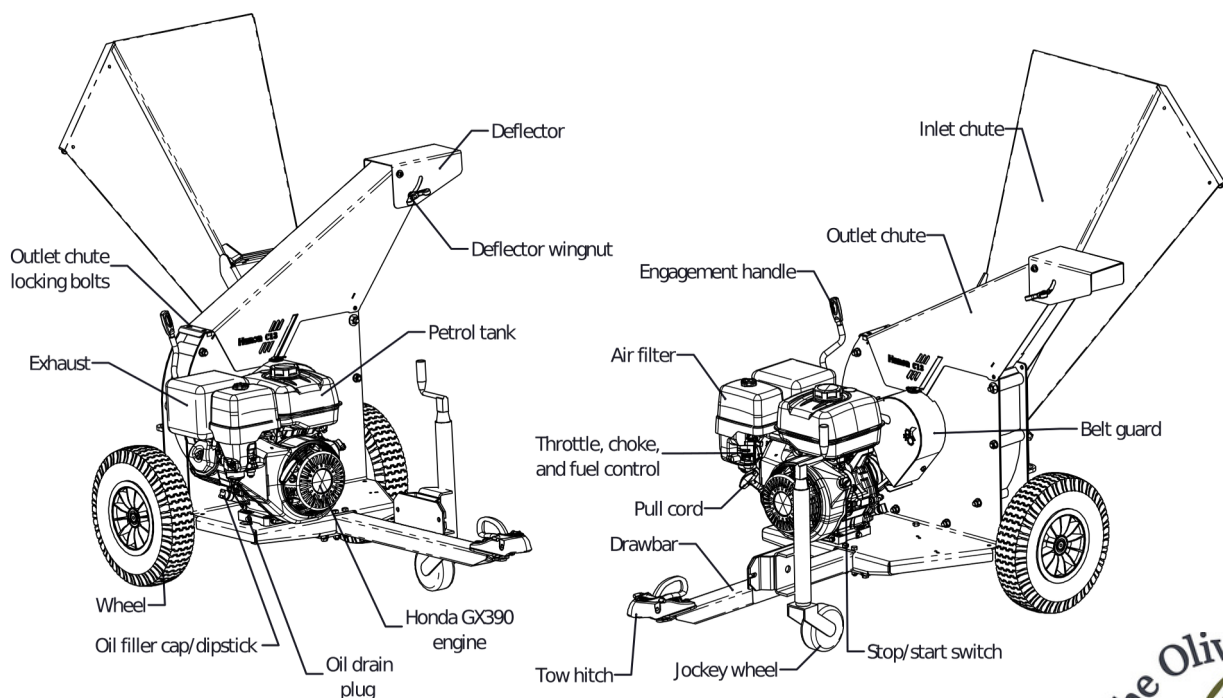

Assembling the chipper

When you receive your Hansa brushchipper, the inlet and outlet chute may not be assembled on the chipper. All the fasteners (bolts, nuts and washers) will be attached to their respective components.

Tools required for assembly (not supplied):

- 16 mm spanner - to fit the inlet and outlet chute 17
- mm spanner - to fit the inlet and outlet chute Two
- 24mm spanners – to fit the fixed outlet chute

Parts supplied for assembly



All **fasteners** included to fix inlet chute and outlet chute onto the chipper



Inlet chute



Fixed outlet chute (if you have purchased a fixed outlet chute model)



Swivel outlet chute (if you have purchased a swivel outlet chute model)



Chipper body

Fit the fixed outlet chute

1



Slide the outlet chute over the black cutting rotor onto the chipper body; the open side of the chute is facing the engagement handle. Fix the outlet chute to the chipper body by tightening the pivot bolt using a 16 mm and 17 mm spanner.

2



Secure the m16 bolt, washers and nut through the hole in the base of the outlet chute to hold the outlet chute shut. Ensure the spring washer is situated between the nut and the heavy washer. Tighten the bolt and nut using two 24mm spanners

Fit the swivel outlet chute

1

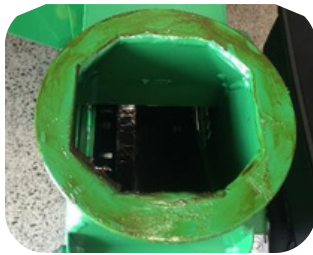

Lightly grease the flange on the chipper body.

2



Slide the outlet chute onto the greased flange of the chipper body, ensuring that the locking hinge is open.

3

Outlet chute locking handle

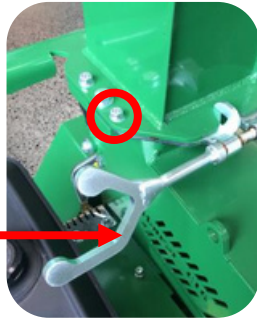

Close the locking hinge and fasten the two m6 bolts, spring washers, and washers to the locking pin on each side of the outlet using a 10 mm spanner. Ensure the spring washer is between the bolt head and washer.

Tighten the outlet chute locking handle to secure the outlet chute to the chipper body.

Note: The outlet chute locking package will be in the documentation package.

Fit the inlet chute

4



Fix the inlet chute - place the inlet chute onto the chipper body with the black rubber flap sandwiched in between and ensure all three holes line up. Tighten the nuts, washers, and bolts using a 16 mm and 17 mm spanner. Ensure that the washer is touching the bolt head.

5



Line up holes and insert the bolts, washers and nuts, ensuring the big washer is touching the bolt head.

Fit the drawbar (optional part)

6

C13 Drawbar Assembly Details

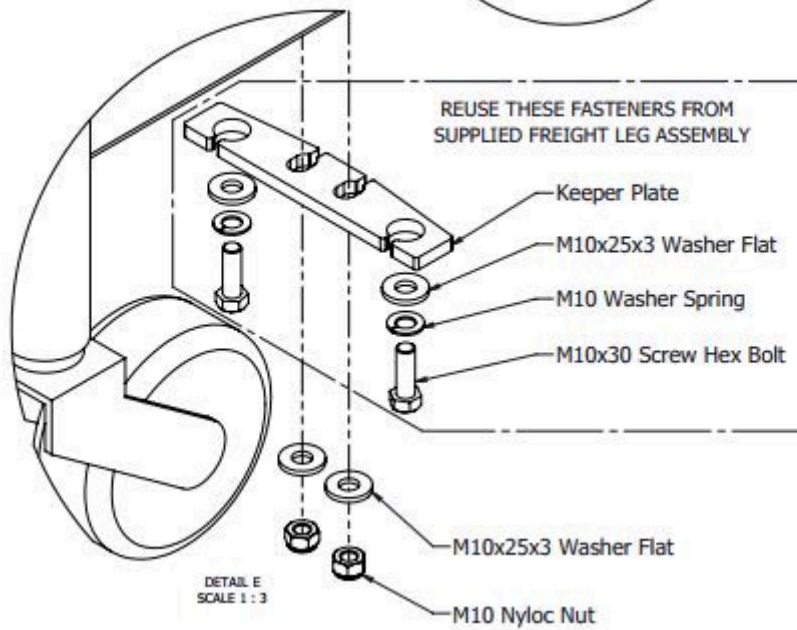
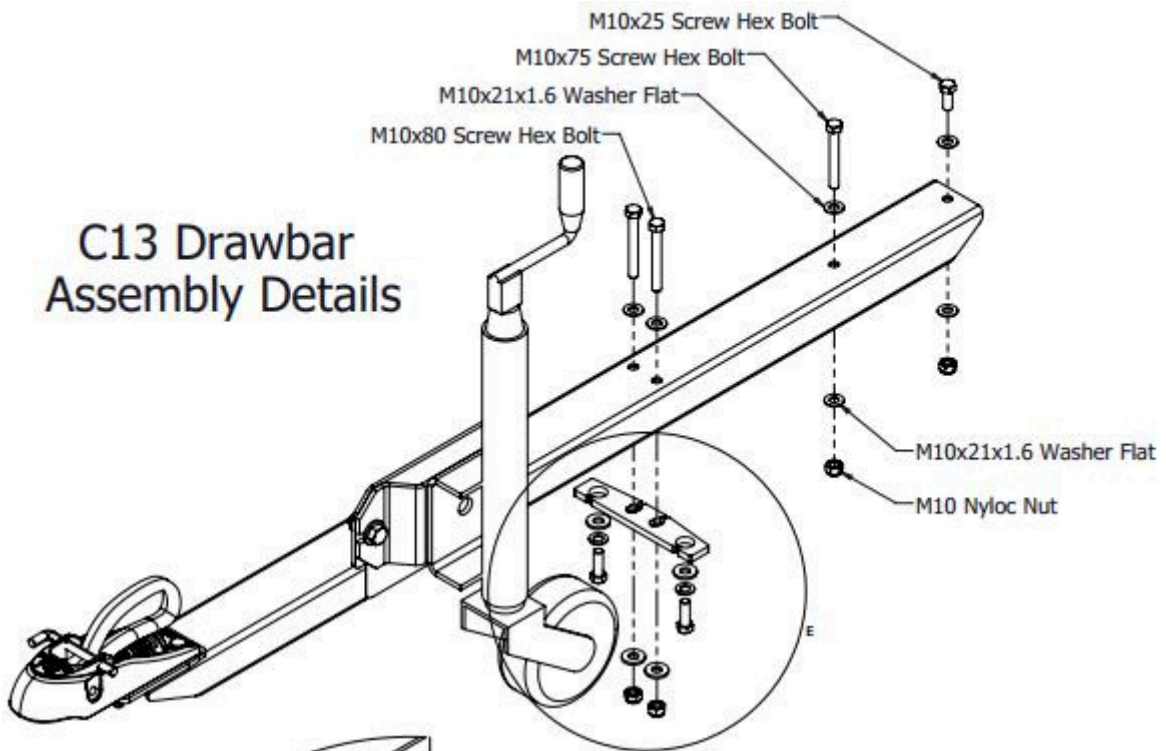

Safety

Preventing accidents is the responsibility of every equipment operator. The operator is responsible for any accidents or hazards occurring to people or their property. Ensure every operator is familiar with the safe operation procedures and controls of the machine, how to identify hazards, and the steps required to avoid injury while handling and operating the chipper. Relevant information is contained in this manual.

- ✘ **Do NOT** modify the design of the chipper.

Operator competency

- ✔ Ensure that every person operating the chipper understands and follows the safe operating and maintenance procedures as detailed in this manual.
- ✘ **Do NOT** allow persons below the age of 18 to operate the chipper. Additionally, local regulations may restrict the age of the operator.
- ✘ **Do NOT** allow persons with reduced physical, sensory or mental capabilities, or lack of experience and knowledge to operate the machine.



















Towing safety (for road-towable model)

- ✔ Connect tow coupling to the towing vehicle (check the ball dimensions are the same as the coupling)
- ✔ Connect safety chain with shackle
- ✔ Plug in lights and check they are operational
- ✔ Check wheel nuts periodically to make sure they are secure
- ✔ Ensure the jockey wheel is in the up position and locked away during travel
- ✔ Ensure that the machine is towed in accordance with local trailer transport regulations

Identifying hazards and risks

Identify hazards and risks, and take preventative steps to avoid accidents and minimise risk. Possible hazards include, but are not limited to, moving parts, thrown objects, weight of chipper and components, and the operating environment.

Below is a list of hazards and actions required to prevent injury.

 Hazard	Risk	Corrective action
 Dust	Injury or irritation of the eyes Respiratory irritation	Wear safety glasses Process freshly cut materials and/or wear a dust mask
 Exhaust Fumes	Respiratory irritation	Place the chipper in a manner that the operator is not exposed to direct exhaust fumes
 Hot Exhaust	Heat burns	Keep bare hands and other body parts a safe distance away from hot exhaust
 Fire	Heat burns	Clear any build-up of chipping debris around the engine and exhaust regularly
 Belt Drive	Skin pinching and/or abrasions	Ensure that the belt guard is in place, and keep away from the belt and its guarding Keep your face and body out of the inlet chute
 Cutting rotor and knives	Pinching, crushing, cutting, severing	<ul style="list-style-type: none">  Do NOT extend hands/arms past the rubber flap  Use a stick to push materials into the inlet chute  Do NOT push the stick beyond the rubber flap
 Sound	Damage to hearing	Always wear hearing protection when operating the machinery
 Discharge material	Eye injury, minor cuts	Always wear safety glasses when operating the machinery <ul style="list-style-type: none">  Do NOT put any body part in front of the outlet chute  Do NOT put the machinery in a place where the outlet chute is directed on a hard surface
 Feeding material	Cuts and scrapes	Wear safety gloves Wear tight fitting long sleeves and pants to cover bare skin when operating the machinery
 Weight of the chipper	Straining, crushing	Place the machinery on firm level ground
 Petrol, oil, grease	Poisoning, skin irritation, harmful vapours	Take care when handling petrol, oil and grease Wash skin if contaminated with petrol, oil or grease <ul style="list-style-type: none">  Do NOT refuel the chipper in enclosed areas

Operation

The chipper is self-feeding and has a large inlet opening. It can process:

- Prunings, stalks, vines, leaves, roots and vegetable matter, paper and cardboard
- Freshly cut material is better to process than dry material
- Maximum capacity is 90 mm diameter branches

It is helpful (but not required) to keep a wooden stick handy, approx. 60 mm diameter x 600 mm long for:

- Pushing in short, brushy and very leafy materials
- Keeping the inlet chute clear



Safe setup procedure

Before you start:

- ✔ Ensure the chipper is positioned in an open area and on firm level ground
- ✔ Ensure that the outlet chute is discharged onto soft ground (e.g. grass)
 - ✘ **Do NOT** allow the outlet chute to discharge chip onto hard surfaces (such as a paved or gravel surface)
 - Ejected material can rebound and cause injury
- ✔ Keep children, pets and spectators clear of the work area at all times
 - ✘ **Do NOT** operate the chipper where there is a hazard to onlookers
 - ✘ **Do NOT** allow any person under the age of 18 to operate the chipper
- ✔ Check:
 - ✔ That all screws, nuts, bolts, and other fasteners are properly secured
 - ✔ That all chipper components are in place and in good condition
 - If any parts are worn or damaged, contact Hansa for replacements
 - ✔ That fuel and engine oil levels are above the minimum levels
 - ✔ That the fuel cap is secured and there is no fuel leaking from the tank
 - ✔ That the inlet chute and housing are clear of any leftover material
 - ✔ That all labels are in good condition and easily legible
 - Replace damaged or unreadable labels
 - View photos of labels in the "Decals" section
 -
- ✔ Refuelling:
 - ⚠ Take extra care in handling fuels
 - They are flammable and vapors are explosive
 - ⚠ Use only an approved fuel container
 - ✔ Always replace and securely tighten fuel cap after refuelling
 - ✔ Allow engine to cool down before refuelling
 - ✔ If you need to drain the fuel, ensure this is done outside
 - ✘ **Do NOT** smoke when using or refuelling the chipper
 - ✘ Never remove fuel cap or add fuel with the engine running
 - ✘ Never refuel the chipper indoors
 - ✘ Never store the chipper or fuel container inside where there is an open flame, such as a water heater
 - ✘ If fuel is spilled, do not attempt to start the engine. Wipe up the spilled fuel, and move the chipper away from the area of spillage before starting

Safe operating procedure



DO:

- ✔ **Wear safety equipment:** Safety glasses, hearing protection and protective gloves must be worn at all times. - ensure that the gloves fit tightly.
- ✔ Tie long hair up
 - Long hair could be pulled into the chipper
- ✔ Wear clothes that sit tightly
 - ⚠ Avoid scarves and any items that can get caught in the chipper



- ✔ Keep your face and body away from the inlet chute
- ✔ Stand clear of the discharge zone, even when no material is being fed into the chipper
- ✔ Place the chipper on even ground and direct the outlet chute onto soft ground
- ✔ Ensure the exhaust is pointing away from the working area and downwind from the operator and onlookers
- ✔ Keep proper balance and footing at all times and stand at the same level as the chipper
 - ✘ **Do NOT** overreach
 - ✘ **Do NOT** run near the machine
- ✔ Feed only freshly cut material into the chipper
 - ✘ **Do NOT** feed in materials covered in gravel, stones and dirt as this can rebound, injure the operator and damage the machinery
- ✔ Prune to a size that suits the chipper's capabilities
- ✔ Pre-cut side branches
 - Branches will 'self-feed' more efficiently
- ✔ Keep the engine clean of debris and other accumulations
 - ⚠ This prevents damage to the engine or possible fire
- ✔ Feed limbs and branches through butt end first, leaving the foliage on
 - This helps guide the limb down the inlet chute
 - It reduces spinning and the occurrence of ejection of small pieces back up the inlet chute
- ✔ Hold larger branches back and feed the chipper with care until you are familiar with its capacity
 - The engine will slow down or stall if the branch is too large
- ✔ Feed longer pieces together with short stubby pieces
- ✔ Feed soft materials intermittently with branches
 - The wood chips tend to clean out any soft residue left in the chipper
 - The chipper can clog up with soft, wet or fibrous materials
 -
- ✔ Keep the outlet free of blockage
 - If a blockage occurs, turn the engine off, disconnect the spark plug, and wait for rotor to stop spinning. Open the outlet chute and remove material until the outlet chute is clear
- ✔ As the discharge material piles up
 - Move the chipper to direct the outlet chute away from the pile, or move the processed material to avoid blocking
- ✔ Turn off the engine whenever you leave the work area

✘ DO NOT:

- ✘ Run the chipper in an enclosed area
 - ⚠ Exhaust fumes contain carbon monoxide which is poisonous, colourless, odourless, and tasteless
- ✘ Operate the chipper wearing loose clothing and untied long hair
- ✘ Stand at a higher level than the base of the chipper when feeding material into it
- ✘ Process old materials such as dried wooden branches
 - They get very hard and springy when dried out
 - They are more awkward to handle
 - The knives dull much quicker
 -
- ✘ Feed short, stubby pieces of wood into the chipper
 - They bounce and spin in the inlet chute
 - ✔ Feed short stubby pieces together with longer pieces
- ✘ Feed branches that are too large
 - The chipper can easily stall
- ✘ Put soil, sand, grit, stones, glass, pieces of metal or other foreign objects into the chipper
 - This will damage the sharp edge of the cutting knives and can rebound and injure the operator
- ✘ Put root balls and dead wood into the chipper
 - This dulls the knives quickly
- ✘ Overload the chipper
 - If the cutting rotor is slowing down, feed the material in slower
- ✘ Allow processed material to build up in the discharge area as this can:
 - Prevent proper discharge
 - Result in kickback of material through the feed opening
- ✘ Transport the chipper while the engine is running
- ✘ Tamper with the engine governor settings on the chipper
 - The governor controls the maximum safe operating speed and protects the engine and all moving parts from

damage caused by overspeed

- ✘ Operate the chipper with blunt knives
 - This causes excessive vibration which may result in damage to the chipper
- ✘ Move or tilt the machine while it is running
- ✘ Touch any guards or stick hands between guards while the chipper is running
- ✘ Put hands or any other part of the body or clothing:
 - Inside the feed chute past the rubber flap
 - Inside or near the opening of the discharge chute
 - Near any moving part
- ✘ Remove any guards on the chipper unless the engine is turned off and the cutting rotor has come to a complete standstill
- ✘ Leave the chipper on while it is unattended



Starting procedure

Before proceeding, ensure the 'safe setup procedure' has been followed on page 8 of this manual.

1

Choke lever ("on" position)



Fuel lever ("on" position)



Turn the choke lever, fuel lever, and engine switch to the "on" position.

2

Throttle lever ("max" position)



Turn the throttle to max position and disengage the belt drive by winding the engagement handle anti clock-wise until it comes to a stop.

3

Pull cord



Pull the pull cord in one smooth motion to start the engine.

4



Once the engine is started and has warmed up (approx. 10 seconds), turn the choke lever to the "off" position (as shown in the picture).

5



To engage the belt drive, slowly rotate the engagement handle clockwise until it comes to a stop.

This must be done slowly to allow the cutting rotor to pick up speed; otherwise the engine may stall.

Shutdown procedure

1



Throttle lever ("min" position)

Turn the throttle lever to the "min" position and wait for the rotor to slow down.

2



Disengage the belt drive by rotating the engagement handle counter clock-wise until it comes to a stop.

3



Turn the engine switch to "off" position.



WARNING! Do NOT disengage the belt drive with the chipper running at full revs, as this will cause friction and vibration on the belt drive.

Petrol



The chipper requires 91 unleaded or E10 petrol to run; check the petrol level before starting.

Storage

- ✔ Always allow the chipper to cool before storing
- ✔ Store the chipper out of the reach of children
- ✔ Store the chipper where fuel vapor will not reach an open flame or spark
- ✔ Switch the fuel lever to the off position
 - For extended storage periods, run the engine dry of fuel
- ✔ Store the chipper out of the rain
 - Water can rust the steel body of the chipper

Troubleshooting



What to do if:

- ? The chipper won't start
 - The engine oil level might be too low
 - The chipper is fitted with oil alert and will not start if the oil level is too low
 - ✔ Check the oil level and top up if required
 - The chipper is placed on a slope
 - The chipper is fitted with oil alert and will not start if the oil is not level
 - ✔ Move the chipper to level ground
- ? Belt drive engagement will not work
 - The inlet chute or housing might be blocked
 - ✔ Turn engine off, disconnect the spark plug wire, ensure rotor has completely stopped, remove debris, restart engine, then attempt to re-engage the belt drive
- ? The chipper slows down and stalls
 - The chipper is clogged up
 - ✔ Turn the engine off, disconnect the spark plug wire, ensure rotor has completely stopped, remove debris, then close and lock the outlet chute
- ? Discharge slows down
 - The chipper is clogged up
 - ✔ Turn the engine off, disconnect the spark plug wire, ensure rotor has completely stopped, remove debris, then close and lock the outlet chute
- ? The chipper is slowing down
 - The chipper can't process the amount of material fed into it
 - ✔ Feed the material in slower
 - ✔ Reduce material volume
- ? The chipper will not self-feed
 - The knives and/or anvil might be blunt
 - ✔ Inspect and sharpen or replace knives and/or anvil as required. Ensure correct clearances between knives and anvil
- ? The material is ejected in long strips
 - The knives and/or anvil might be blunt

- ✔ Inspect and sharpen or replace knives and/or anvil as required. Ensure correct clearances between knives and anvil
- ❓ The chipper is clogged
 - ✔ Turn the engine off, disconnect the spark plug wire, ensure rotor has completely stopped, remove debris, then close and lock the outlet chute
- ❓ The chipper starts making unusual noise, the cutting rotor strikes a foreign object or the chipper starts to vibrate
 - ✔ Turn the engine off, disconnect the spark plug wire, ensure rotor has completely stopped, then inspect for damage
 - ✔ Replace or repair any damaged parts
 - ✔ Check for and tighten any loose parts
 - ❌ **Do NOT** attempt to repair the chipper unless you are competent to do so



WARNING! Do NOT open the housing unless the engine and cutting rotor have completely stopped.

Maintenance

Maintain the chipper with care and keep it clean at all times.

To service or inspect the equipment, or to change an accessory, you must:

- ✔ Switch the engine off
- ✔ Allow the chipper to cool before any inspections or adjustments
- ✔ Wait until the cutting rotor and engine are at a complete standstill before opening the cutting rotor housing
- ✔ Disconnect the spark plug wire from the spark plug
- ✔ Switch fuel lever to off position



Disconnected spark plug

Initially after 2 working hours:

- ✔ Check for any loose nuts and bolts
- ✔ Check belt tension (refer to belt tension section)
 - The belts will stretch when they are new
- ✔ Grease the two rotor bearings, one at the front and one at the back of the housing
 - One or two pumps are sufficient
 - Be careful not to over grease
 - The bearings are greased when the equipment is new
 - Use bearing grease or all-purpose grease

Every 20 working hours:

- ✔ Check for any loose nuts and bolts
- ✔ Check belt tension (refer to belt tension section)
- ✔ Grease two bearings as above, be careful not to over grease
- ✔ Check sharpness of knives
- ✔ Check condition of guarding (belt guard and outlet chute)
 - A damaged guard must be replaced by an identical or equivalent guard immediately. It is recommended to contact Hansa for a replacement guard.
 -



EQUIPMENT | MACHINERY | ADVICE

www.theolivecentre.com

Code: CA3C13-P

Knife re-sharpening and knife replacement

How do I know that the knives need re-sharpening?

- Chipper loses its self-feeding action with blunt knives
- Material has to be pushed in
- Material comes out in long strips



WARNING! Do NOT operate your chipper with blunt knives.

- Blunt knives will cause excessive vibration
- Blunt knives result in damage to the chipper

How to re-sharpen the knives:

If you don't have a surface grinder or are unsure how to re-sharpen the knives, contact a professional saw doctor or Hansa to arrange re-sharpening.



WARNING! Be careful when working around the sharp knives. Be aware that even though engine is switched off, the cutting means can still move.

Tools and materials required for re-sharpening (approx. 40 mins):

- 13 mm spanner
- 6 mm hexagonal Allen key
- A stick magnet (optional)
- Surface grinder
- Coolant

Remove the knives for sharpening

1

Open the rotor housing cover by removing the two housing cover locking bolts with an 18 mm spanner, then lift the rotor housing cover to access the cutting rotor.

Rotate the cutting rotor to gain access to the knives, then engage the belt drive to stop the cutting rotor from rotating.

2



Use a 13 mm spanner to remove the knives from the cutting rotor. There are five bolts that you must remove to do so.

- Be careful not to drop the bolts or knives into the chipper
- A stick magnet can be used to retrieve them if this does occur

3



Measure the width of the knife and check that it will be at least 46 mm after sharpening.

If the knives will be shorter than 46 mm, then the knives should be replaced. Please contact your nearest Hansa dealer.

Sharpen the knives

4



Sharpen the knives on a surface grinder. A cutting angle of 36° is critical for the performance of the chipper. Make sure plenty of coolant is used when grinding to avoid softening of the steel knives.

Reinstall the knives

5

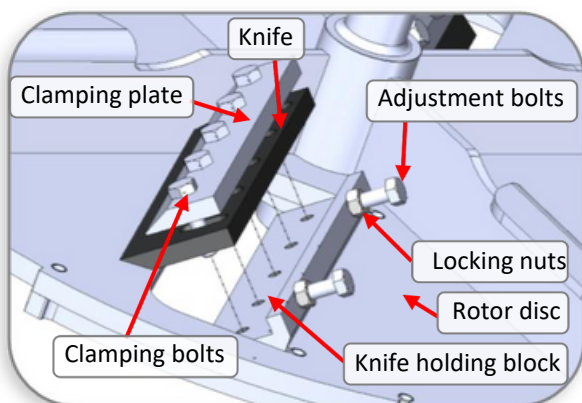

Clean all mounting surfaces and remount the knives in the reverse procedure.

Note: Be sure to replace the knives the correct way around (as shown in the diagram). Only tighten the clamping bolts enough to hold the knives in place during adjustment. Do not tighten them fully until step 7.

6

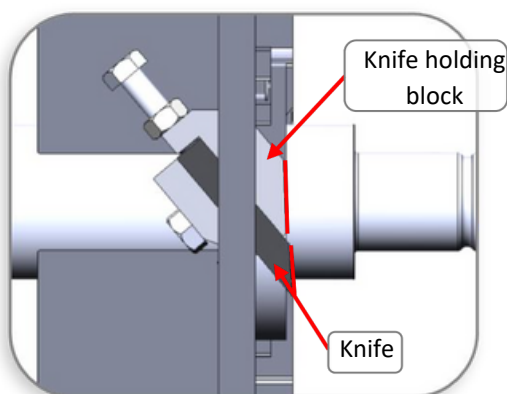

Adjust the knives initially using the adjustment bolts to protrude the edge of the knife just past the edge of the knife holding block.

Side view: Cutting rotor



Out of the pocket enough



Not far enough out of pocket

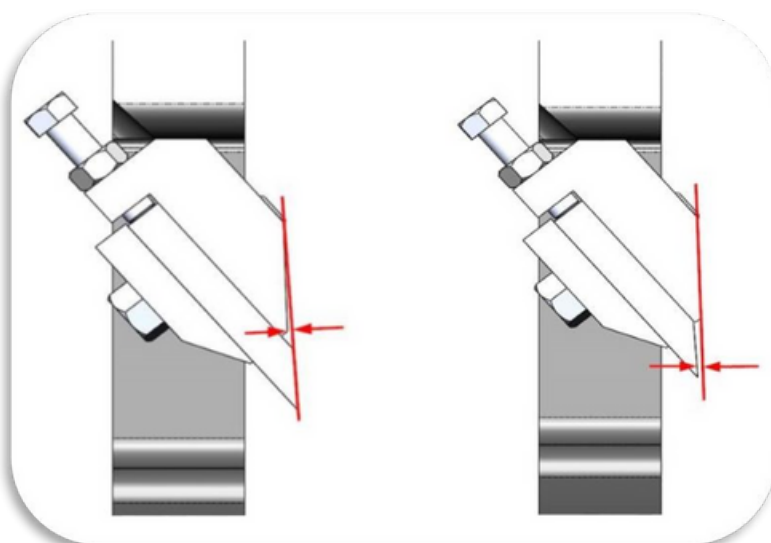

✔ Correct knife angle
 ✘ Incorrect knife angle

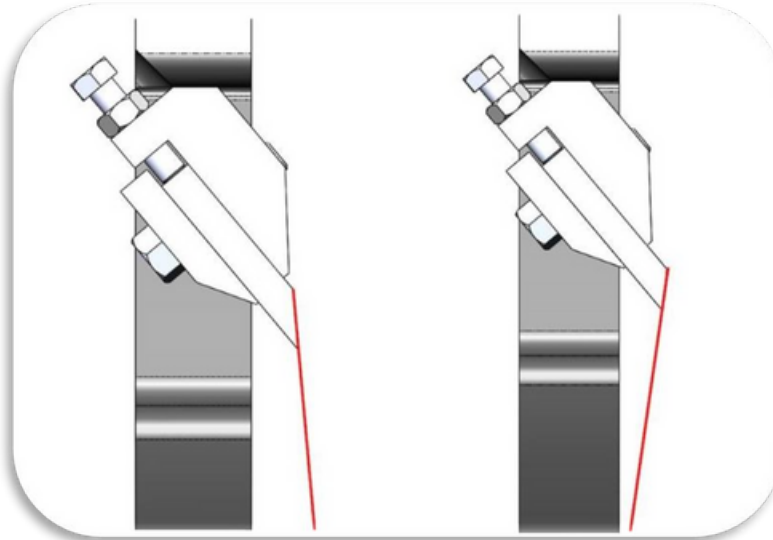

7

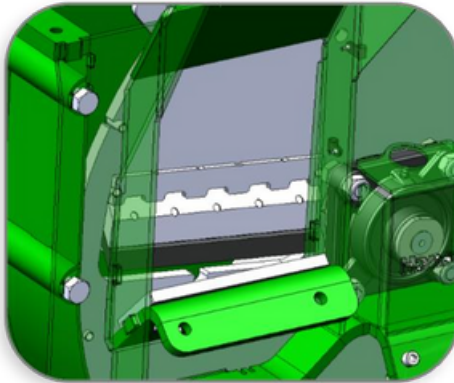

After sharpening, the width of the knives will have been reduced, therefore the gap between the knives and anvil may require adjustment. This gap is tapered out slightly to allow for a small amount of movement in the cutting rotor as it bites into the wood.

If there is not enough clearance, the knife edge may touch the anvil through deflection when cutting heavy branches and damage the sharp edge. Too much clearance will allow small twigs and fibrous materials to be dragged through without being cut.

Adjust the knife in or out using the two adjustment bolts to achieve the correct clearance between the knife and anvil. The clearance between the knife and anvil should be approximately 1 mm on the inside closest to the bearing and 3 mm on the outside closest to the edge of the cutting rotor (refer to diagram for more detail).

After the correct clearance is set, fully tighten the clamping bolts using a torque wrench to 35 Nm and tighten the locking nuts on the adjustment bolts.

Note: Before adjusting the knives, ensure the gap between the holding block and the anvil is 4 - 5 mm. If not, then the anvil can be adjusted through the mounting slots. Once the position has been set, tighten the three M10 countersunk anvil bolts and torque to 50 Nm, then make further adjustments with the knives as described above.

Turn the cutting rotor slowly by hand to check that it turns freely.

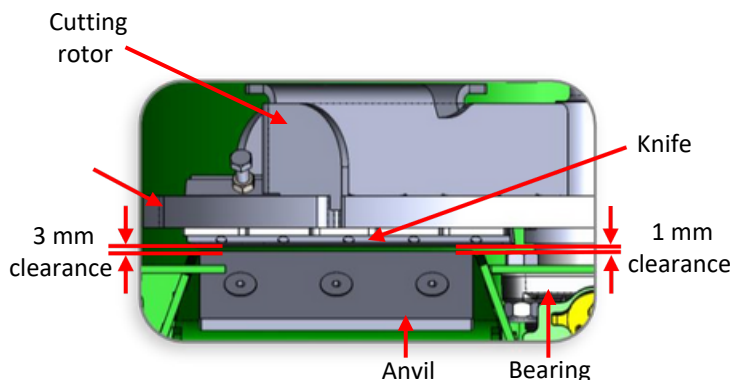

Top view: Knife and anvil set-up



Close and secure the outlet chute.



WARNING! Every time the knife clamping bolts are torqued up to 35 Nm and loosened off again, the life of the bolts is reduced. The knife clamping bolts must be replaced at most after every six sharpens. Contact Hansa for replacement bolts (m8x35 bolts of grade 8.8 or higher). Use only genuine Hansa bolts.

Anvil adjustment/replacement

When cutting edge of the anvil is dull, the anvil may be reversed can be reversed. Each edge of the anvil will typically last for several hundred hours of operation. When both edges are worn, the anvil will need to be replaced.

To access the anvil the inlet chute needs to be removed (use the reverse procedure to fit the inlet on page 4). A 6 mm Allen key, 17 mm socket and an extension are required to remove the anvil.

With the knives removed or set right back, the gap between the knife holding block and anvil should be 4 - 5 mm. The position of the anvil can be adjusted through the mounting slots. When this has been set, tighten the three M10 countersunk anvil bolts using a torque wrench to 50 Nm and then make further adjustments with the knives as described above.

Turn the cutting rotor slowly by hand to check that it turns freely.

Engine servicing

For servicing of the engine, please refer to the Honda engine manual.

Engine oil

It is recommended you check the oil level every time you use your chipper. To check the oil level, unscrew the oil filler cap/dipstick, clean the dipstick, then insert the dipstick without screwing it into the thread. Fill as necessary, using the diagram as a reference. For optimal performance of your chipper, the engine oil should be completely changed every 100 operating hours, or roughly once every 12 months on average.

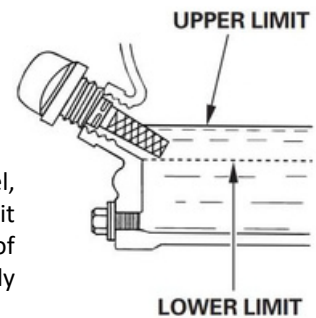

If the engine oil needs to be changed, follow these steps:

1

Oil filler cap/dipstick
Oil drain plug

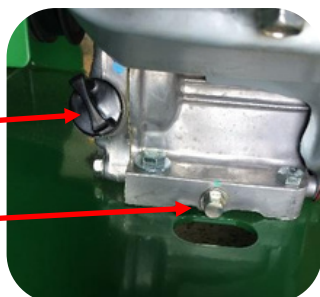

Run the engine for 1-2 minutes in order to warm up the oil. Switch the engine off after the oil is warm. Place a container underneath the engine. Remove oil filler cap/dipstick and oil drain plug (using a 10 mm spanner), then let the oil drain into the container through the opening in the chassis.

2

Screw the oil outlet drain plug back in and fill the engine with 1.1 Litres of SAE 10W30 or SAE 10W40 through the oil filler cap/dipstick hole (the oil should reach the thread near the hole opening).

3

Check the oil level after filling, ensure it is close to, but not greater than the upper limit. Screw the oil filler cap/dipstick back into the hole. Dispose of the used engine oil in an environmentally sensitive way.

Belt tension

Correct belt tension is crucial for minimising belt wear and maximising machine efficiency. To check the belt tension, first ensure the belt drive is disengaged by turning the engagement handle anticlockwise. Then, from the fully disengaged position, gently turn the engagement handle clockwise until you feel it start to resist. From this position, turn the engagement handle clockwise. If the tension is set correctly, the handle should turn one full revolution clockwise before coming to a stop. If there is a difference greater than 1/6 of a revolution either clockwise or anticlockwise from one full revolution, then the belt tension should be corrected following the 'adjusting belt tension' procedure.

Adjusting belt tension

1

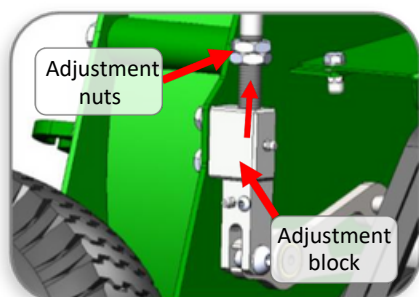

Using two 24 mm spanners, unlock the two locking nuts from above the adjustment block on the engagement handle by turning the top nut anti clockwise and the bottom nut clockwise. Then move both locking nuts upward along the thread.

2

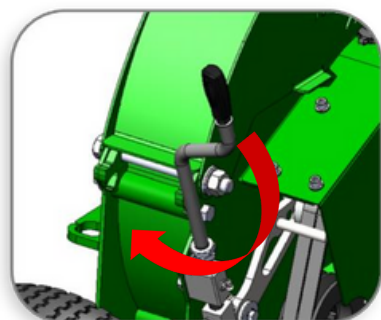

Rotate the handle clockwise until you start to feel the belt stretching and beginning to resist. From this position, turn the engagement handle one full revolution in the clockwise direction. This is the recommended tension for the belt drive when in the fully engaged position.

3

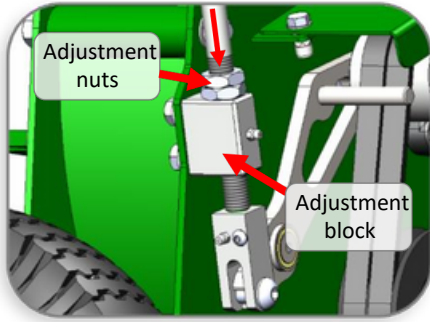

Once the tension is set, use two 24 mm spanners to screw the two M16 adjustment nuts downwards until they touch the adjustment block. Then turn the top nut clockwise and the bottom nut anti clockwise simultaneously to lock the nuts in place.

Belt replacement

If the belts in your chipper look similar to any of the following images or are clearly broken, then they need to be replaced.

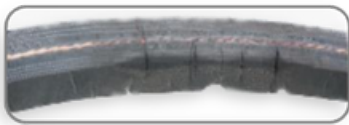

Cracked underside of belt



Split belt cover

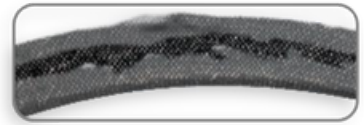

Soft, swollen belt



Worn cover on back of belt



Sidewall belt wear

If a belt change is necessary, follow these steps

1

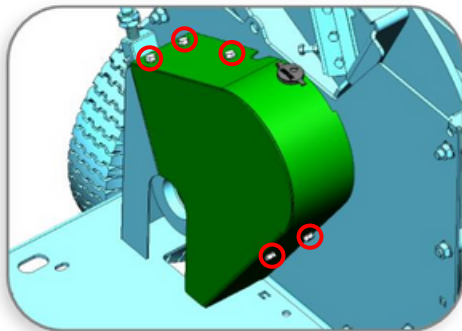

Using a 6 mm Allen key, unbolt and remove the pulley guard (5 x M8 bolts).

Note: Engine not shown in this view.

2

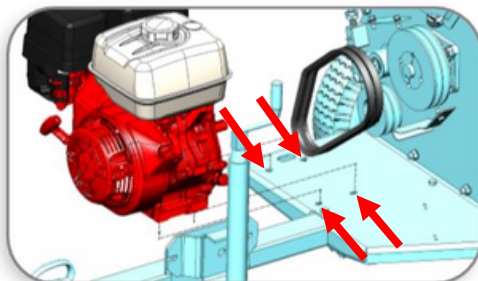

Using two 17 mm spanners, unbolt and remove the engine (4 x M10 nuts).

Note: Loosen the belt tensioner to allow room for removal.

3

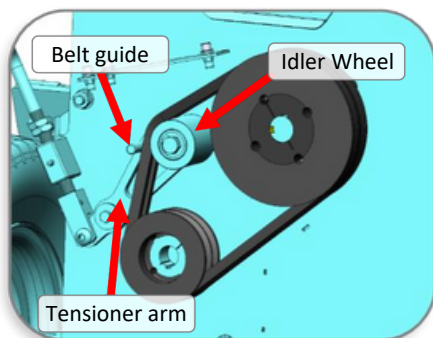

Remove the old belts and replace (2 x B34 vee belts).

Note: The belts pass in between the idler wheel and belt guide on the tensioner arm.

4

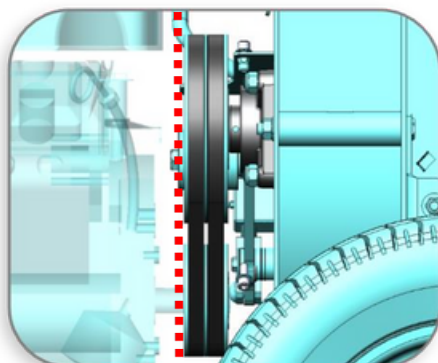

Place engine back in place and ensure the pulleys are in line. Check the pulleys are still in line by placing a straight edge across the top and bottom front pulley. If they are not in line, loosen the four bolts holding the engine to the chassis and repeat this step.

5

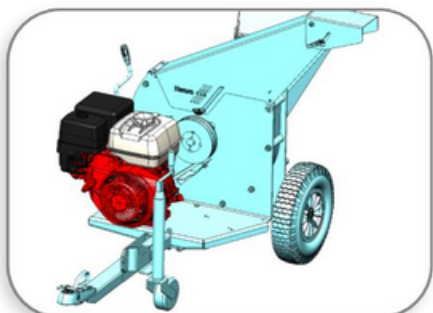

Fully tighten the four bolts holding the engine to the chassis. After fully tightening the bolts, check to make sure the pulleys are still in line.

6

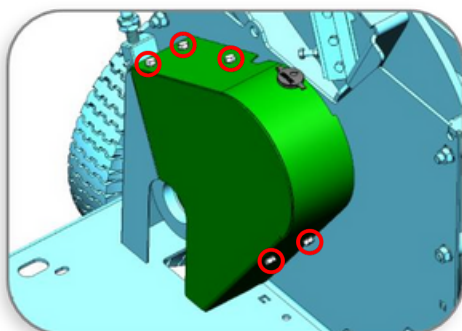

Ensure belts are properly tensioned (follow the 'Adjusting belt tension' process on page 18). Fasten the pulley guard back into place.

Note: Engine not shown in this view.

Note that after replacing a belt, the tension of the new belt will quickly change as the belt initially wears into the pulley system. Recheck the belt tension after two hours of operation after belt replacement.

Tyre pressure

The maximum recommended tyre pressure for the non-road towable model is 25 Psi.

The maximum recommended tyre pressure for the larger wheels on the road towable model is 65 Psi.

Do NOT over inflate the tyres. Over inflation may cause tyres to rupture.

Bolt torque

		Relative Strength Bolt Marking			
		4.6		8.8	
		Recommended Tightening Torque		Recommended Tightening Torque	
Bolt size	Spanner size	lb ft	Nm	lb ft	Nm
M8	13 mm	6	8.5	16	22
M10	16 mm	12.5	17	32	44
M12	18 mm	22	30	57	77
M16	24 mm	54	73	140	190
M20	30 mm	105	143	274	372

Specifications

		C13ST 2050 mm 1145 mm 1495
General	Length	mm 198-208 kg
	Width	Honda GX340
	Height	13 HP
	Weight	2000 RPM
Motor	Make & model	560 x 12 mm
	Max Power	31.75 mm
Cutting System	Disc speed	2
	Disc dimensions	90 mm
	Shaft diameter	Gravity fed, self-feeding
	Knives	170 x 220 mm
Feed System	Chipping capacity	1085 mm (1400 Swivel)
	Feed type	Fixed/Swivel outlet with deflector
	Inlet chute opening	
Discharge System	Discharge height	
	Outlet chute type	

Safety Labels

Safety Label Locations

With fixed outlet chute:

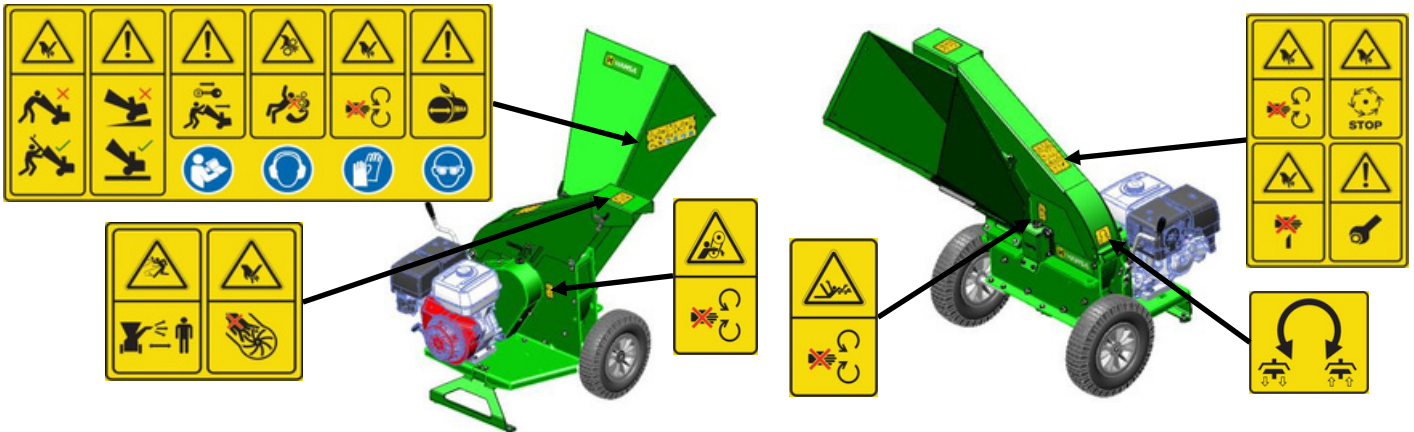



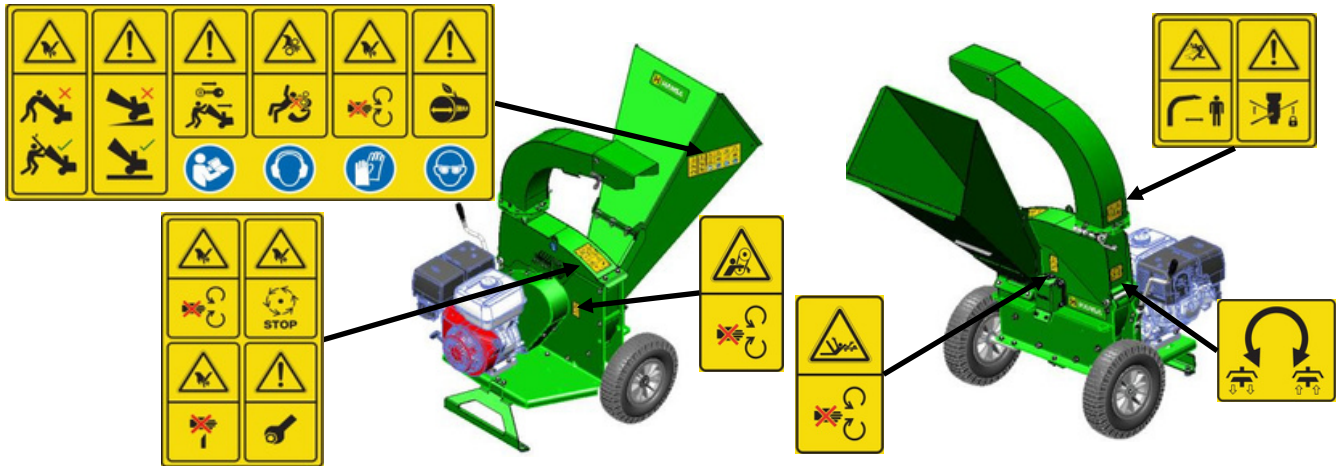





















With swivel outlet chute:



Safety Label Explanations

Instructions manual must be read.	Ear protection must be worn.	Tight and heavy-duty gloves must be worn.	Eye protection must be worn.	(Fixed outlet chute) Stay clear of outlet discharge area. Keep bystanders away.	(Swivel outlet chute) Stay clear of outlet discharge area. Keep bystanders away.	(Swivel outlet chute) Stay clear of outlet discharge area. Lock outlet when machine is running.	(Swivel outlet chute) Stay clear of outlet discharge area. Lock outlet when machine is running.

							
							
Use only wooden stick to clear blockage.	Operate only on stable level ground.	Turn machine off before moving.	Do not operate with loose clothing or long hair.	Do not extend hands down inlet chute past rubber flap.	Max 90 mm branch capacity.	Keep clear while machine is running.	Keep clear while machine is running.

					
					
Do not open while machine is running.	Do not touch moving components.	Take care while working with sharp blades.	Fasten outlet before starting machine.	Turn anticlockwise to disengage.	Turn clockwise to engage.

HANSA global industrial limited warranty

For the purposes of this warranty document, "HANSA" means HANSA Products Limited and any of its international subsidiary companies. Refer to contact details below for further information.

HANSA warrants each new HANSA chipper ("HANSA product") free from defects in materials and workmanship under normal use and routine servicing, for the warranty periods and subject to the limitations and exclusions detailed below.

HANSA offers a special extended warranty period ("Extended Warranty") to new HANSA products purchased from an authorised HANSA dealer. The Extended Warranty period is set out below. In order to take advantage of the Extended Warranty you must:

1. Register your HANSA product through the HANSA warranty registration process and identify your HANSA product by its machine serial number. **Registration must be completed with ten (10) days from the date of purchase.** Your warranty registration confirmation email is your identification for warranty service; and
2. Have your registered HANSA product maintained in accordance with the schedule contained in the relevant owner's manual supplied with the product by an authorised HANSA dealer for the applicable territory. In order to ensure the safe operation of your HANSA product, we strongly recommend that you only use an authorised HANSA dealer for servicing. The cost of routine or required maintenance and services is the responsibility of the purchaser. You must keep a record of all service and maintenance history as proof of servicing history. HANSA may request such servicing history when assessing any future warranty claim.

When making a claim for warrantable repairs under the Extended Warranty, your warranty registration must accompany the HANSA product. If the warranty registration is lost or destroyed, proof of purchase documentation clearly recognising the machine serial number shall be accepted for warranty purposes. Where neither is available and HANSA does not have any record of the purchaser's details the warranty period shall be calculated from the appropriate dealer wholesale sale date. Any claim under the applicable Warranty must be made within the relevant warranty period specified below.

The Extended Warranty may be subject to cancellation if the above requirements are not satisfied.

The Extended Warranty is available to domestic (non-commercial) and commercial customers (excluding commercial customers in the business of plant/equipment hire).

All HANSA products that have not complied with the Extended Warranty registration and maintenance requirements are entitled to the "Non-Registered" warranty period set out below.

Any authorised HANSA dealer is further authorised to repair or replace any part which proves defective within the limits of the Extended Warranty or Non-Registered Warranty (the "Warranties") at no charge to the owner, covering parts and labour. Consumable items such as but not limited to oils, grease, blades and belts shall be the responsibility of the owner. All defective parts replaced under the Warranties become the property of HANSA.

You (as owner) are responsible for all shipping and transportation costs (including insurance) to and from an authorised HANSA dealer for the product subject to a warranty claim.

Exclusions

The warranties shall NOT APPLY TO:

- Any damage which results from neglect of periodic maintenance specified by HANSA. Any damage which results from repair or maintenance operations by methods other than specified by HANSA. Any damage which results from misuse or use beyond the limitations of the intended use specified by HANSA in the operation, maintenance and safety manual, such as overloading, including foreign objects such as stones, pieces of steel, glass etc. being dropped into the running machine or use under abnormal conditions (in HANSA's sole judgement). Any damage which results from use of non-genuine parts, lubricant or fluid not approved by HANSA. Any damage resulting from modification or installation in other products in a way not approved by HANSA which has any influence on the function and/or performance of the products. Any damage which results from operation other than specified in the Owner's Manual either intentionally or by error. Fading of painted surfaces, deterioration of plated surfaces, deterioration of rubber and plastics, including rusting due to the passage of time.
- Normal phenomena such as noise, vibration or oil seepage which are considered by HANSA as not affecting the quality, function or performance of the product.
- Any damage due to improper storage or transport.
- Consumable replacement items: Belts, cutting blades, anvil, serviceable bearings.
- Periodical maintenance items such as cleaning, inspection and adjustments.
- Any repair and/or adjustment performed by persons other than an authorised dealer, or damage resulting therefrom. Any repair and/or adjustment to correct improper or poor quality work previously performed.

- Incidental expenses incurred in the warranty claim. For example: additional expenses such as those for towing, communications, hotel and meals, incurred due to breakdown of the product at a remote location. Any expense related to personal injury and/or property damage, (exclusive of the product itself). Compensation for loss of time, commercial losses or rental costs of a substitute product during the period of adjustment. Any damage which results from unavoidable natural disasters, fire, collision, theft, etc. Any normal wear or deterioration, such as that of sliding or rotating parts caused under normal operating conditions. For example: Normal wear pivot points, rod ends and bearings. Any damage resulting from exposure of the product to soot and smoke, medicines and chemical agents, sea water, sea breeze, salt or other environmental phenomena.

Limitations

- HANSA reserves the right to modify, alter and improve any product without incurring any obligation to replace any product previously sold with such modification.
- In no event shall HANSA's liability exceed the purchase price of the product.
- Equipment and accessories not of HANSA's manufacture (such as engine, battery and tires) are warranted only to the extent of the original manufacturer's warranty and subject to their allowance to HANSA only if found to be defective by such manufacturer.
- HANSA reserves the right to supply remanufactured parts as it deems appropriate.

HANSA Product Warranty Period

HANSA CHIPPERS	COMMERCIAL		
	DOMESTIC	(EXCLUDING HIRE)	COMMERCIAL (HIRE)
Non-Registered	12 months	12 months	3 months
Extended Warranty	36 months (Conditional)*	36 months (Conditional)*	N/A

Each of the warranty periods stated above commence from the date on which you purchased your HANSA product.

*Conditional Warranty:

This is a HANSA extended warranty period for products that are:

- Purchased from an authorised HANSA Dealer.
- Registered at the time of sale through the Hansa Chippers website: www.hansaproducts.com/registration
- Serviced by a HANSA Dealer in accordance with the Hansa service schedule using genuine HANSA parts.
- Extended Warranty is limited to 36 months or 1000 hours, whichever occurs first.
- Meeting all other warranty requirements.

Warranty periods vary depending on whether the purchaser is: (i) a domestic (i.e. non-commercial) customer; (ii) commercial customer (excluding plant/equipment hire businesses); or (iii) a commercial customer in the business of plant/equipment hire.

General

- Your rights:
 - HANSA will recognise any implied rights and remedies that are available to you at law in the applicable territory and that cannot be excluded by HANSA.
 - In New Zealand, Hansa Products Ltd will recognise your statutory rights under the Consumers Guarantee Act 1993 (provided that you are a consumer for the purposes of that Act).
 - In Australia, this warranty is given by Hansa Products Pty Ltd. This warranty is provided in addition to other rights and remedies you have under law - our HANSA products come with guarantees that cannot be excluded under the Australian Consumer Laws.
- If any provision of this warranty document is held by any competent authority to be invalid or unenforceable in whole or in part, the validity of the other provisions of this warranty document and the remainder of the provisions in question will not be affected. The English language version of this warranty document prevails over any translated version/s of its terms.
- warranty document is governed by the laws of New Zealand. The parties submit to the exclusive jurisdiction of the New Zealand Courts.

Contact Details

New Zealand:

Hansa Products Limited
PO Box 10323, Te Rapa

Rest of World:

Please refer to www.hansaproducts.com
for a current list of our authorised dealers

Commissioning checklist and registration



It is the retailers' responsibility to ensure that this chipper is correctly commissioned for use, and that the purchase is registered with Hansa Chippers so as to provide the owner with the full benefit of the warranty policy.

Product registration must be completed online:

www.hansaproducts.com/registration

For registration, you will require the chipper serial number and customer details.

It is the retailers' responsibility to check the following:

Final Assembly	Check all bolts for tightness including knives
Operation	Instruct the owner/operator on operating procedures and techniques
Safety	Instruct owner/operator on safety procedures
Maintenance	Explain the maintenance requirements and the importance of following the maintenance schedule to the owner/operator
Manual	Emphasise the importance of reading and understanding the manual in full before initial operation of the chipper