

HANSA C7

Operation, maintenance and safety manual

The Olive Centre

EQUIPMENT | MACHINERY | ADVICE

www.theolivecentre.com

Code: CA30A



All operators must fully read and understand this operator's manual before using the chipper.

Keep this manual for future reference.



3 YEAR | **GLOBAL WARRANTY**

Register your Hansa chipper to qualify
www.hansaproducts.com/registration



TABLE OF CONTENTS

WHAT CAN MY HANSA CHIPPER PROCESS?	1
INTENDED USES OF THE CHIPPER	1
RECEIVING YOUR HANSA CHIPPER	1
CHIPPER COMPONENTS	1
ASSEMBLY	3
SAFETY	6
OPERATOR COMPETENCY	6
IDENTIFYING HAZARDS AND RISKS	6
OPERATION	7
SAFE SETUP PROCEDURE	7
SAFE OPERATING PROCEDURE	8
STARTING PROCEDURE	9
SHUTDOWN PROCEDURE	11
PROCESSING FIBROUS MATERIAL	11
PETROL	12
STORAGE	12
TRANSPORTATION	12
TROUBLESHOOTING	13
WHAT TO DO IF :	13
MAINTENANCE	14
KNIFE RE-SHARPENING AND KNIFE REPLACEMENT	14
ENGINE SERVICING	17
ENGINE OIL	17
BELT TENSION	17
BELT REPLACEMENT	18
TYRE PRESSURE	20
BOLT TORQUE	20
SPECIFICATIONS	21
SAFETY LABELS	21
SAFETY LABEL LOCATIONS	21
SAFETY LABEL EXPLANATIONS	22
HANSA GLOBAL INDUSTRIAL LIMITED WARRANTY	23
COMMISSIONING CHECKLIST AND REGISTRATION	25

What can my Hansa chipper process?

Intended uses of the chipper

The Hansa C7 chipper is built to process organic material including wooden branches not exceeding 70 mm in diameter. It is designed to be used on a regular basis to maintain large gardens, lifestyle blocks and acreages. **Do NOT** use the chipper for any other purpose.

Organic wastes include:

- ✔ Prunings, stalks, roots, vegetable matter, hay, grass, bark
- ✔ Dry manure
- ✔ Branches
- ✔ Palm fronds
- ✔ Dead and hard timbers (Note: these will dull the knives faster)
- ✔ Paper or cardboard



Do NOT process:

- ✘ Bones
- ✘ Soil, root balls, sand, grit, stones, metal

If you have any questions, contact your authorised dealer.

 **Do NOT** exceed 70 mm branch diameter

Receiving your Hansa chipper

You may receive your chipper assembled from your dealer or it may be packaged in two boxes. Assembly takes approximately 30

minutes, two people working together will make the assembly easier.

Chipper components

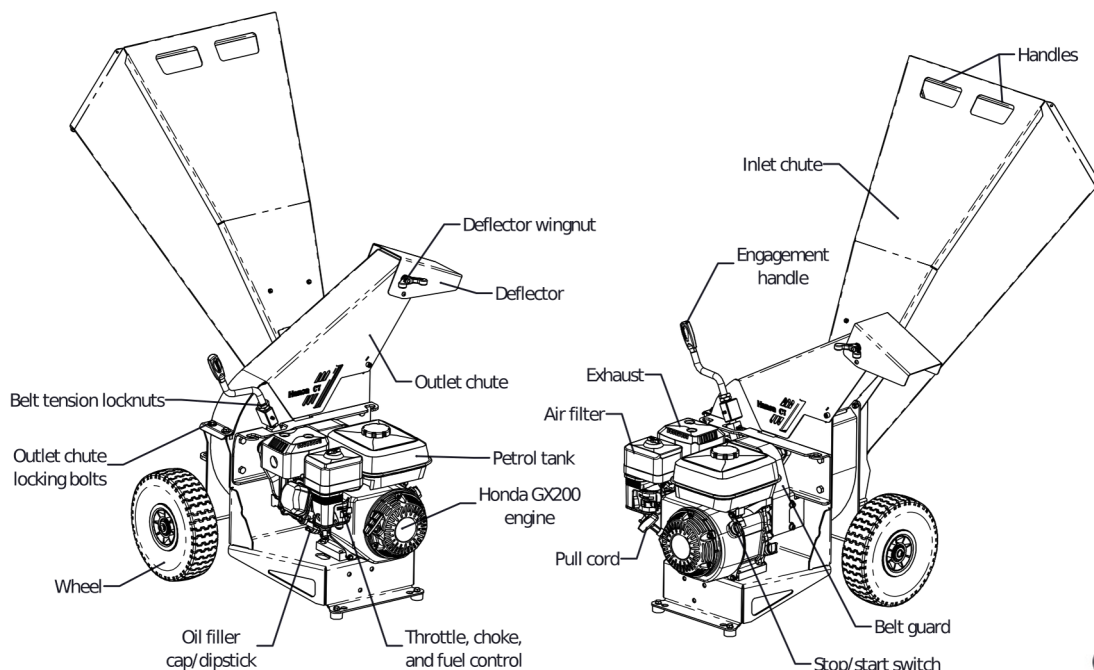

Tools required for assembly (not supplied):

- A knife to cut open the box
- Two 13 mm spanners - to tighten the inlet chute
- 14 mm spanner - to tighten the swivel handle
- 16 mm spanner - to unscrew and tighten the axles
- 6 mm Allen key - to tighten the wheels and the screws on the outlet chute

Box 1 contains:

- ✓ The chipper body
- ✓ Two wheels
- ✓ A cardboard block for support of the chipper body for wheel attachment



All the C7 parts in two separate boxes



Contents in box 1



Wheels and cardboard block



Chipper body



CAUTION: The chipper body weighs 70 kg; it is recommended to cut the box open rather than lifting the body out.

Box 2 contains:



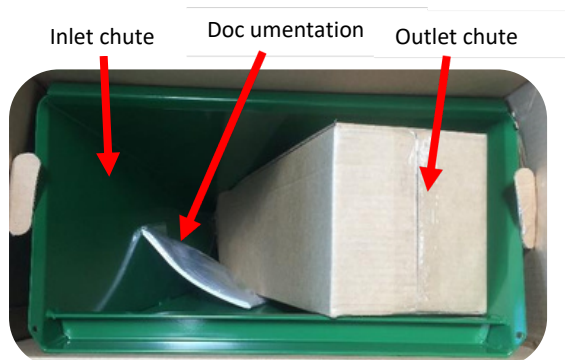





- ✓ The inlet chute
- ✓ A fastener pack containing parts required for assembly
- ✓ The outlet chute; packed into a separate cardboard box
- ✓ Documentation (Hansa operations manual, warranty card and Honda motor manual)



Contents in box 2



Fastener pack

Item no.	Fastener pack contents (in box 2)	
1		One big spring washer for swivel handle
2		Two small spring washers for wheels
3		One swivel handle
4		Two bolts, spring washers, heavy washers, and nuts used to fix the inlet chute to the chipper body
5		Two washers to fix wheels onto the axle
6		Four cap screws to attach the wheels and outlet chute to the chipper body
7		Two nyloc nuts to fix screws on outlet chute
8		Two bolts, spring washers, and heavy washers , used to fix the outlet chute to the chipper body

Assembly

Assemble the chipper body

1



Place the cardboard block underneath the chipper body - this makes it easier to attach the wheels.

2

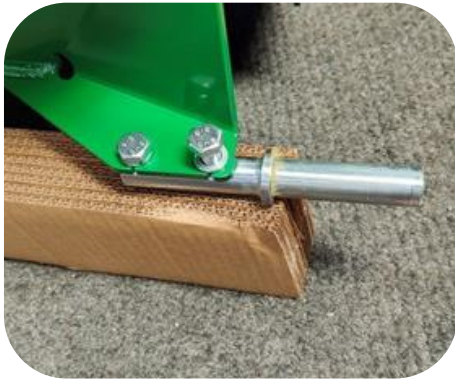

Loosen the screws of the axles, move the axles out and re-tighten the bolts.

3



Slide the wheels onto the axles. Ensure valve is facing outwards.

4



Using a 6 mm Allen key, fasten the wheels to the chipper body. Use the small spring washers (item no. 2), cap screws (item no. 6), and big washers (item no. 5) to do so. Ensure the big washer is touching the wheel followed by the smaller spring washers, then the bolt head.

Fit the outlet chute

5



Slide the outlet chute over the black cutting rotor onto the body; the open side of the chute is facing the engagement handle. Fix the outlet chute to the chipper body by tightening the cap screws (item no. 6) and nyloc nuts (item no. 7) using a 6 mm Allen key and 13 mm spanner.

6



Fix the other side of the outlet to the chipper body by inserting two heavy washers, two spring washers, and two 16 mm m8 bolts (item no. 8) into the threaded holes on the chipper body. Ensure the spring washer sits between the bolt head and heavy washer. Use a 13 mm spanner to ensure these are fully tightened.

Fit the inlet chute



7



Fix the inlet chute - check that it slides in on the top, and at the bottom. If the holes don't fit to tighten the screws, the best option is to take the chute out and re-insert it.



8



Line up the holes and insert the bolts, washers and nuts (item no. 4), ensuring the big washer is touching the bolt head (top) and the spring washer is touching the nut (bottom).

Attach the swivel handle

9



Attach the swivel handle (item no. 3) to the engagement handle using a 14mm spanner. Ensure the spring washer (item no. 1) is placed on the thread of the engagement handle before tightening it.

Safety

Preventing accidents is the responsibility of every equipment operator. The operator is responsible for any accidents or hazards occurring to people or their property. Ensure every operator is familiar with the safe operation procedures and controls of the machine, how to identify hazards, and the steps required to avoid injury while handling and operating the chipper. Relevant information is contained in this manual.

- ❌ **Do NOT** modify the design of the chipper.

Operator competency

- ✅ Ensure that every person operating the chipper understands and follows the safe operating and maintenance procedures as detailed in this manual.
- ❌ **Do NOT** allow persons below the age of 18 to operate the chipper. Additionally, local regulations may restrict the age of the operator.
- ❌ **Do NOT** allow persons with reduced physical, sensory or mental capabilities, or lack of experience and knowledge to operate the machine.

Identifying hazards and risks

Identify hazards and risks, and take preventative steps to avoid accidents and minimise risk. Possible hazards include, but are not limited to, moving parts, thrown objects, weight of chipper and components, and the operating environment.

Below is a list of hazards and actions required to prevent injury.

Hazard	Risk	Corrective action
⚠️ Dust	Injury or irritation of the eyes Respiratory irritation	Wear safety glasses Process freshly cut materials and/or wear a dust mask
⚠️ Exhaust Fumes	Respiratory irritation	Place the chipper in a manner that the operator is not exposed to direct exhaust fumes
⚠️ Hot Exhaust	Heat burns	Keep bare hands and other body parts a safe distance away from hot exhaust
⚠️ Fire	Heat burns	Clear any build-up of chipping debris around the engine and exhaust regularly
⚠️ Belt Drive	Skin pinching and/or abrasions	Ensure that the belt guard is in place, and keep away from the belt and its guarding Keep your face and body out of the inlet chute
⚠️ Cutting rotor and knives	Pinching, crushing, cutting, severing	<ul style="list-style-type: none"> ❌ Do NOT extend hands/arms past the rubber flap ✅ Use a stick to push materials into the inlet chute ❌ Do NOT push the stick beyond the rubber flap

⚠ Sound	Damage to hearing	Always wear hearing protection when operating the machinery
⚠ Discharge material	Eye injury, minor cuts	Always wear safety glasses when operating the machinery <ul style="list-style-type: none"> ❌ Do NOT put any body part in front of the outlet chute ❌ Do NOT put the machinery in a place where the outlet chute is directed on a hard surface
⚠ Feeding material	Cuts and scrapes	Wear safety gloves Wear tight fitting long sleeves and pants to cover bare skin when operating the machinery
⚠ Weight of the chipper	Straining, crushing	Place the machinery on level ground
⚠ Petrol, oil, grease	Poisoning, skin irritation, harmful vapours	Take care when handling petrol, oil and grease Wash skin if contaminated with petrol, oil or grease <ul style="list-style-type: none"> ❌ Do NOT refuel the chipper in enclosed areas

Operation

The chipper is self-feeding and has a large inlet opening. It can process:

- Prunings, stalks, vines, leaves, roots and vegetable matter, paper and cardboard
- Freshly cut material is better to process than dry material
- Maximum capacity is 70 mm diameter branches

It is helpful (but not required) to keep a wooden stick handy, approx. 60 mm diameter x 600 mm long for:

- Pushing in short, brushy and very leafy materials
- Keeping the inlet chute clear



Safe setup procedure

Before you start:

- ✔ Ensure the chipper is positioned in an open area and on firm level ground
- ✔ Ensure that the outlet chute is discharged onto soft ground (e.g. grass)
 - ❌ **Do NOT** allow the outlet chute to discharge chip onto hard surfaces (such as a paved or gravel surface)
 - ☐ Ejected material can rebound and cause injury
- ✔ Keep children, pets and spectators clear of the work area at all times
 - ❌ **Do NOT** operate the chipper where there is a hazard to onlookers
 - ❌ **Do NOT** allow any person under the age of 18 to operate the chipper
- ✔ Check:
 - ✔ That all screws, nuts, bolts, and other fasteners are properly secured
 - ✔ That all chipper components are in place and in good condition
 - ☐ If any parts are worn or damaged, contact Hansa for replacements
 - ✔ That fuel and engine oil levels are above the minimum levels
 - ✔ That the fuel cap is secured and there is no fuel leaking from the tank
 - ✔ That the inlet chute and housing are clear of any leftover material
 - ✔ That all labels are in good condition and easily legible
 - ☐ Replace damaged or unreadable labels
 - ☐ View photos of labels in the "Decals" section
- ✔ Refuelling:
 - ⚠ Take extra care in handling fuels
 - ☐ They are flammable and vapors are explosive
 - ⚠ Use only an approved fuel container
 - ✔ Always replace and securely tighten fuel cap after refuelling
 - ✔ Allow engine to cool down before refuelling
 - ✔ If you need to drain the fuel, ensure this is done outdoors

- ❌ **Do NOT** smoke when using or refuelling the chipper
- ❌ Never remove fuel cap or add fuel with the engine running
- ❌ Never refuel the chipper indoors
- ❌ Never store the chipper or fuel container inside where there is an open flame, such as a water heater
- ❌ If fuel is spilled, do not attempt to start the engine. Wipe up the spilled fuel, and move the chipper away from the area of spillage before starting

Safe operating procedure

✔ DO:

- ✔ **Wear safety equipment:** Safety glasses, hearing protection and protective gloves must be worn at all times. - ensure that the gloves fit tightly.
- ✔ Tie long hair up
 - Long hair could be pulled into the chipper
- ✔ Wear clothes that sit tightly
 - ⚠ Avoid scarves and any items that can get caught in the chipper
- ✔ Keep your face and body away from the inlet chute
- ✔ Stand clear of the discharge zone, even when no material is being fed into the machine
- ✔ Place the chipper on even ground and direct the outlet chute onto soft ground
- ✔ Ensure the exhaust is pointing away from the working area and downwind from the operator and onlookers
- ✔ Keep proper balance and footing at all times and stand at the same level as the chipper
 - ❌ **Do NOT** overreach
 - ❌ **Do NOT** run near the chipper
- ✔ Feed only freshly cut material into the chipper
 - ❌ **Do NOT** feed in materials covered in gravel, stones and dirt as this can rebound, injure the operator and damage the machinery
- ✔ Prune to a size that suits the chipper's capabilities
- ✔ Pre-cut side branches
 - Branches will 'self-feed' more efficiently
- ✔ Keep the engine clean of debris and other accumulations
 - ⚠ This prevents damage to the engine or possible fire
- ✔ Feed limbs and branches through butt end first, leaving the foliage on
 - This helps guide the limb down the inlet chute.
 - It reduces spinning and the occurrence of ejection of small pieces back up the inlet chute
- ✔ Hold larger branches back and feed the chipper with care until you are familiar with its capacity
 - The engine will slow down or stall if the branch is too large
- ✔ Feed longer pieces together with short stubby pieces
- ✔ Feed soft materials intermittently with branches
 - The wood chips tend to clean out any soft residue left in the chipper
 - The chipper can clog up with soft, wet or fibrous materials
- ✔ Keep the outlet free of blockage
 - If a blockage occurs, turn the engine off, disconnect the spark plug wire, and wait for rotor to stop spinning. Open the outlet chute and remove material until the outlet chute is clear
- ✔ As the discharge material piles up
 - Move the chipper to direct the outlet chute away from the pile, or move the processed material to avoid blocking
- ✔ Turn off the engine whenever you leave the work area



❌ DO NOT:

- ❌ Run the chipper in an enclosed area
 - ⚠ Exhaust fumes contain carbon monoxide which is poisonous, colourless, odourless, and tasteless
- ❌ Operate the chipper wearing loose clothing and untied long hair
- ❌ Stand at a higher level than the base of the chipper when feeding material into it
- ❌ Process old materials such as dried wooden branches

- They get very hard and springy when dried out
- They are more awkward to handle
- The knives dull much quicker
- ✘ Feedshort, stubby pieces of wood into the chipper
 - They bounce and spin in the inlet chute
 - ✔ Feed short stubby pieces together with longer pieces
- ✘ Feed branches that are too large
 - The chipper can easily stall
- ✘ Put soil, sand, grit, stones, glass, pieces of metal or other foreign objects into the chipper
 - This will damage the sharp edge of the cutting knives and can rebound and injure the operator
- ✘ Put root balls and dead wood into the chipper
 - This dulls the knives quickly
- ✘ Overload the chipper
 - If the cutting rotor is slowing down, feed the material in slower
- ✘ Allow processed material to build up in the discharge area as this can:
 - Prevent proper discharge
 - Result in kickback of material through the feed opening
- ✘ Transport the chipper while the engine is running
- ✘ Tamper with the engine governor settings on the chipper
 - The governor controls the maximum safe operating speed and protects the engine and all moving parts from damage caused by overspeed
- ✘ Operate the chipper with blunt knives
 - This causes excessive vibration which may result in damage to the chipper
- ✘ Move or tilt the machine while it is running
- ✘ Touch any guards or stick hands between guards
- ✘ Put hands or any other part of the body or clothing:
 - Inside the feed chute past the rubber flap
 - Inside or near the opening of the discharge chute
 - Near any moving part
- ✘ Remove any guards on the chipper unless the engine is turned off and the cutting rotor has come to a complete standstill
- ✘ Leave the chipper on while it is unattended

Starting procedure

Before proceeding, ensure the 'safe setup procedure' has been followed on page 7 of this manual.

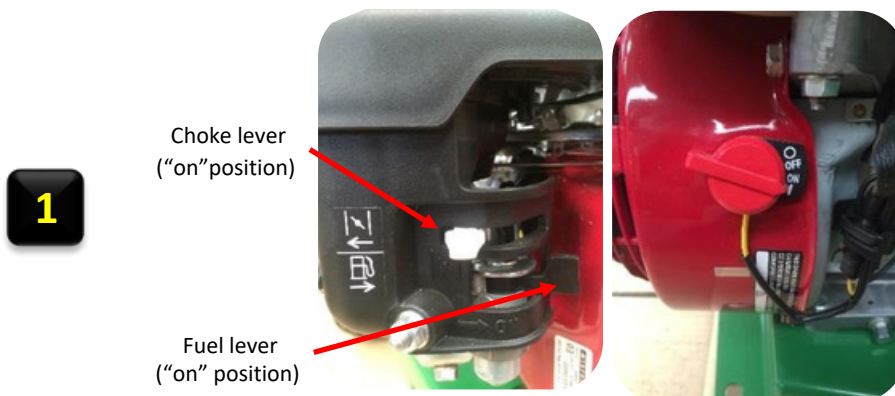

Ensure the emergency stop is disengaged. Turn the choke lever, fuel lever, and engine switch to the "on" position.

2

Throttle lever ("max" position)



Turn throttle to "max" position and disengage the belt drive by winding the engagement handle anti clock-wise until it comes to a stop.

3

Pull cord



Pull the pull cord in one smooth motion to start the engine.

4



Once the engine is started and has warmed up (approx. 30 seconds), turn the choke lever to the "off" position (as shown in the picture).

5

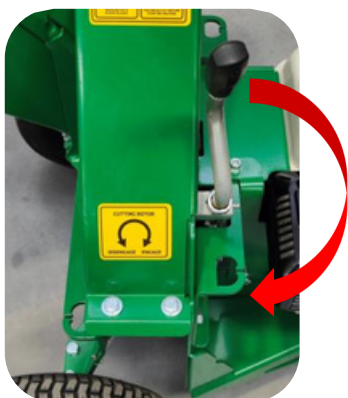

To engage the belt drive, slowly rotate the engagement handle clockwise until it comes to a stop.

This must be done slowly to allow the cutting rotor to pick up speed; otherwise the engine may stall.

Shutdown procedure

1

Throttle lever ("min" position)



Turn the throttle lever to the "min" position and wait for the rotor to slow down.

2



Disengage the belt drive by rotating the engagement handle anti clock-wise until it comes to a stop.

3

Fuel lever ("off" position)



Turn the engine switch and fuel lever to the "off" position.



WARNING! Do NOT disengage the belt drive with the chipper at full revs, as this will cause friction and vibration on the belt drive.

Processing fibrous material

The C7 can process palm fronds, flax, cabbage tree leaves and other similar fibrous material. The machine's cutting disk is cantilevered (supported on the engine side with two bearings), therefore there is no risk of anything fibrous wrapping around the shaft and working its way into the bearings. The resulting output is not as consistent as that of branch material due to the fibrous nature. When processing fibrous material, take note of the following points:

- ✔ Blades must be sharp to process fibrous material
- ✔ Fibrous material is best introduced to the machine as a bundle
- ✔ Fibrous material should be introduced slowly into the machine. Tease the material in and out while feeding it into the cutting mechanism, ensuring it is not drawn through the machine without being cut properly
 - ✘ **Do NOT** extend hands past the rubber flap while doing so
- ✔ Fibrous material is processed more effectively when it is green rather than when dried

Petrol



The chipper requires 91 unleaded or E10 petrol to run; check the petrol level before starting.

Storage

- ✔ Always allow the chipper to cool before storing
- ✔ Store the chipper out of the reach of children
- ✔ Store the chipper where fuel vapor will not reach an open flame or spark
- ✔ Switch the fuel lever to the off position
 - ☐ For extended storage periods, run the engine dry of fuel
- ✔ Store the chipper out of the rain
 - ☐ Water can rust the steel body of the chipper

Transportation

The C7 is designed to be moved by one person using both handles at the top of the inlet chute to lean the chipper backwards and transfer its weight onto the wheels. The chipper can then be wheeled to and from the work location.

- ⚠ Take care when moving the C7 up and down stairs or kerbs
 - ☐ The wheels can be damaged by the shock loading caused by uncontrolled ascent/descent
 - The chipper is heavy and the operator can lose control of the machine
- ✘ **Do NOT** move the chipper while it is running

For long distance transport by means of a vehicle, the C7 may be transported as a single unit or with the inlet and/or outlet chute removed. If it is being transported in parts, then ensure the body of the chipper is upright and stable. If being transported as a single unit, then ensure that the C7 is secured by a strap via the tie-down points on the front and back of the rotor enclosure.

- ✘ **Do NOT** attempt to lift the chipper with less than 3 able-bodied people
 - ☐ The chipper weighs approximately 95 kg
- ⚠ Take care when handling chipper components
 - ☐ Chipper body has a mass of 70 kg
 - ☐ Inlet chute assembly has a mass of 20 kg
 - ☐ Outlet chute assembly has a mass of 6 kg
- ✔ Ensure there is no debris or water trapped in the housing that may spill during transit.
- ✔ Ensure the engine fuel valve is in the OFF position and that the engine is kept upright and stable



Troubleshooting



What to do if:

- ❓ The chipper won't start
 - The engine oil level might be too low
 - The chipper is fitted with oil alert and will not start if the oil level is too low
 - ✔ Check the oil level and top up if required
 - The chipper is placed on a slope
 - The chipper is fitted with oil alert and will not start if the oil is not level
 - ✔ Move the chipper to level ground
- ❓ Belt drive engagement will not work
 - The inlet chute or housing might be blocked
 - ✔ Turn engine off, disconnect the spark plug wire, ensure rotor has completely stopped, remove debris, restart engine, then attempt to re-engage the belt drive
- ❓ The chipper slows down and stalls
 - The chipper is clogged up
 - ✔ Turn the engine off, disconnect the spark plug wire, ensure rotor has completely stopped, remove debris, then close and lock the outlet chute
- ❓ Discharge slows down
 - The chipper is clogged up
 - ✔ Turn the engine off, disconnect the spark plug wire, ensure rotor has completely stopped, remove debris, then close and lock the outlet chute
- ❓ The chipper is slowing down
 - The chipper can't process the amount of material fed into it
 - ✔ Feed the material in slower
 - ✔ Reduce material volume
- ❓ The chipper will not self-feed
 - The knives and/or anvil might be blunt
 - ✔ Inspect and sharpen or replace knives and/or anvil as required. Ensure correct clearances between knives and anvil
- ❓ The material is ejected in long strips
 - The knives and/or anvil might be blunt
 - ✔ Inspect and sharpen or replace knives and/or anvil as required. Ensure correct clearances between knives and anvil
- ❓ The chipper is clogged
 - ✔ Turn the engine off, disconnect the spark plug wire, ensure rotor has completely stopped, remove debris, then close and lock the outlet chute
- ❓ The chipper starts making unusual noise, the cutting rotor strikes a foreign object or the chipper starts to vibrate
 - ✔ Turn the engine off, disconnect the spark plug wire, ensure rotor has completely stopped, then inspect for damage
 - ✔ Replace or repair any damaged parts
 - ✔ Check for and tighten any loose parts
 - ✖ **Do NOT** attempt to repair the chipper unless you are competent to do so



WARNING! Do NOT open the housing unless the engine and cutting rotor have completely stopped.

Maintenance

Maintain the chipper with care and keep it clean at all times.

To service or inspect the equipment, or to change an accessory, you must:

- ✓ Switch the engine off
- ✓ Allow the chipper to cool before any inspections or adjustments
- ✓ Wait until the cutting rotor and engine are at a complete standstill before opening the cutting rotor housing
- ✓ Disconnect the spark plug wire from the spark plug
- ✓ Switch fuel lever to off position

Initially after 2 working hours:

- ✓ Check for any loose nuts and bolts
- ✓ Check belt tension (refer to belt tension section)
 - The belts will stretch when they are new
- ✓ Grease the two rotor bearings, one on the inside and one on the outside of the housing
 - One or two pumps are sufficient
 - Be careful not to over grease
 - The bearings are already greased when the equipment is new
 - Use bearing grease or all-purpose grease

Every 20 working hours:

- ✓ Check for any loose nuts and bolts
- ✓ Grease two bearings as above, be careful not to over grease
- ✓ Check sharpness of knives
- ✓ Check condition of guarding (belt guard and outlet chute)
- ✓
 - A damaged guard must be replaced by an identical or equivalent guard immediately
 - It is recommended to contact Hansa for a replacement guard.

Knife re-sharpening and knife replacement

How do I know that the knives need re-sharpening?

- Chipper loses its self-feeding action with blunt knives
- Material has to be pushed in
- Material comes out in long strips
- Blunt knives result in damage to the chipper
-
-

How to re-sharpen the knives

If you don't have a surface grinder or are unsure how to re-sharpen the knives, contact a professional



Disconnectedsparkplug

WARNING! Do NOT operate your chipper with blunt knives.

saw doctor or Hansa to arrange re-sharpening.

WARNING! Be careful when working around the sharp knives. Be aware that even though the engine is switched off, the cutting means can still move.

Tools and materials required for re-sharpening (approx. 40 mins)

- 13 mm spanner
- 6 mm hexagonal Allen key
- A stick magnet (optional)
- Surface grinder
- Coolant

Remove the knives for sharpening

1

Open the rotor housing cover by removing the two outlet chute locking bolts with a 13 mm spanner, then lift the rotor housing cover to access the cutting rotor. Rotate the cutting rotor to gain access to the knives, then engage the belt drive to stop the cutting rotor from rotating.

2



Use a 13 mm spanner to remove the knives from the rotor. There are three nuts you must remove to do so.

- If the bolt head turns, hold it with a 6 mm hexagonal Allen key
- **Note: Do NOT** try to loosen the bolt with the hexagonal Allen key
Be careful not to drop the nuts, bolts, washers or knives into the chipper
A stick magnet can be used to retrieve them if this does occur

3



Measure the width of the knife and check that it will be at least 35 mm after sharpening. If the knives will be shorter than 35 mm, then the knives should be replaced. Please contact your nearest Hansa dealer.

Sharpen the knives

4



Sharpen the knives on a surface grinder. A cutting angle of 40° is critical for the performance of the chipper. Make sure plenty of coolant is used when grinding to avoid softening of the steel knives.

Reinstall the knives

5

Clean all mounting surfaces and remount the knives in the reverse procedure. Tighten the nuts using a torque wrench to 22 Nm.

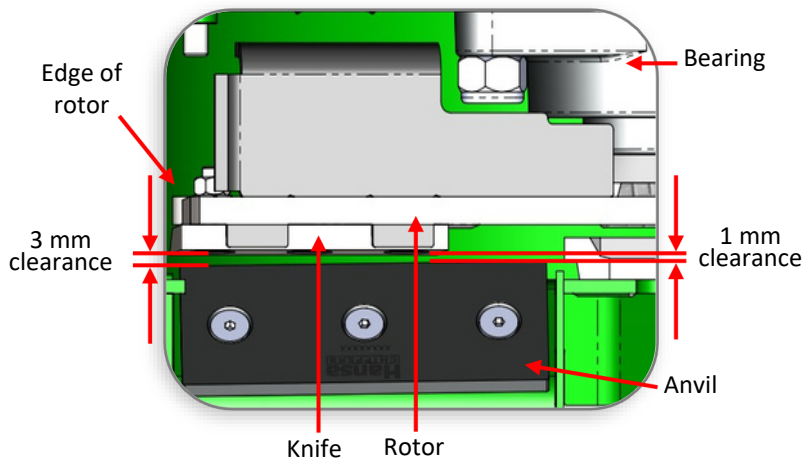

Top view: Outer knife and anvil set-up

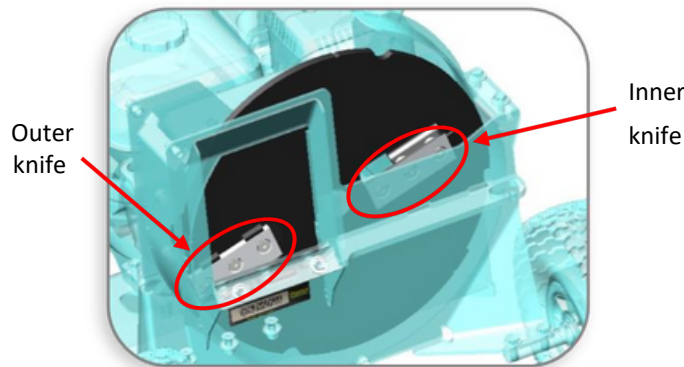

6

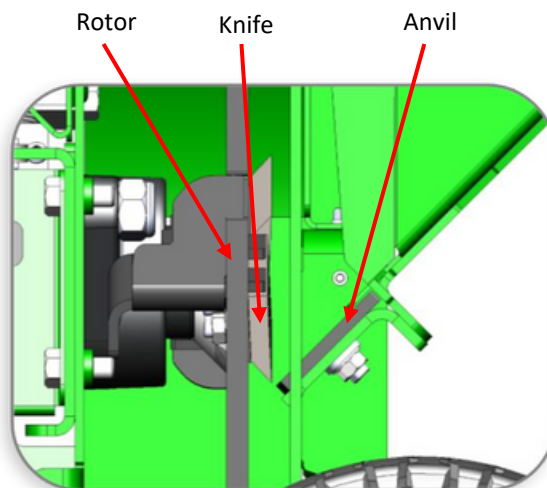

Side view: Knife and anvil set-up

7

Close and secure the outlet chute.

Adjust the anvil at this stage as the location of knife edge will change after sharpening or replacement. The anvil is reversible. Normally the edge will last for over 200 operating hours. When the edge is dull, it can be reversed. When both edges are worn, the anvil should be replaced (contact Hansa for a replacement).

The clearance between the knife and anvil should be approx. 1 mm on the inside closest to the bearing and 3 mm on the outside closest to the edge of the rotor (refer to diagram for more detail). Ensure you are using the outer blade of the rotor for calibrating these distances.

The gap between the knives and the anvil is tapered out slightly to allow for a small amount of movement in the rotor as it bites into the wood.

The anvil position can be adjusted by loosening the anvil mounting bolts. Once adjusted correctly, tighten the anvil mounting nuts using a torque wrench to 22 Nm.

If there is not enough clearance, the knife edge may touch the anvil through deflection when cutting heavy branches and damage the sharp edge. Too much clearance will allow small twigs and fibrous materials to be dragged through without being cut.

Turn the cutting rotor by hand to check that it turns freely.



WARNING! Every time the knife clamping bolts are torqued up to 22 Nm and loosened off again, the life of the bolts is reduced. The knife clamping bolts must be replaced at most after every six sharpens. Contact Hansa for replacement bolts (m8x30 countersunk bolts of grade 12.9 or higher). Use only genuine Hansa bolts.

Engine servicing

For servicing of the engine, please refer to the Honda engine manual.

Engine oil

It is recommended you check the oil level every time you use your chipper. To check the oil level, unscrew the oil filler cap/dipstick, clean the dipstick, then insert the dipstick without screwing it into the thread. Fill as necessary, using the diagram as a reference. For optimal performance of your chipper, the engine oil should be completely changed every 100 operating hours, or roughly once every 12 months on average.

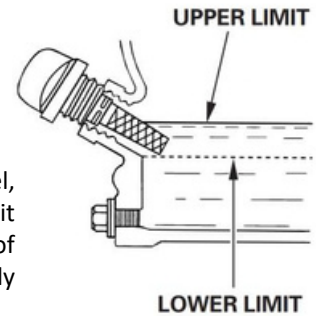

If the engine oil needs to be changed, follow these steps:

1

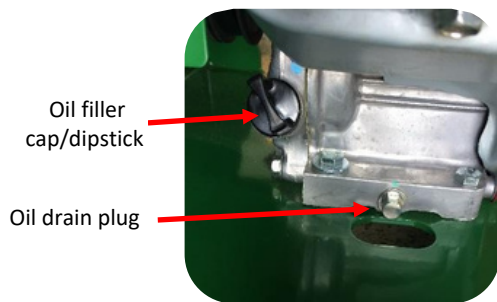

Run the engine for 1-2 minutes to warm up the oil. Switch the engine off after the oil is warm. Place a container underneath the engine. Remove oil filler cap/dipstick and oil drain plug (using a 10 mm spanner), then let the oil drain into the container through the opening in the chassis.

2

Screw the oil outlet drain plug back in and fill the engine with 0.6 Litres of SAE 10W30 or SAE 10W40 through the oil filler cap/dipstick hole (the oil should reach the thread near the hole opening).

3

Using the dipstick, check the oil to make sure it is at the right level (close to the upper limit, but not over). Screw the oil filler cap/dipstick back into the hole. Dispose of the used engine oil in an environmentally sensitive way.

Belt tension

Correct belt tension is crucial for minimising belt wear and maximising machine efficiency. To check the belt tension, first ensure the belt drive is disengaged by turning the engagement handle anticlockwise. Then, from the fully disengaged position, gently turn the engagement handle clockwise until you feel it start to resist. From this position, turn the engagement handle clockwise. If the tension is set correctly, the handle should turn one full revolution clockwise before coming to a stop. If there is a difference greater than 1/6 of a revolution either clockwise or anticlockwise from one full revolution, then the belt tension should be corrected following the 'adjusting belt tension' procedure.

Adjusting belt tension

1

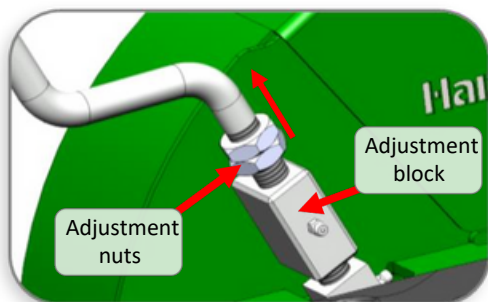

Using two 24 mm spanners, unlock the two locking nuts from above the adjustment block on the engagement handle by turning the top nut anticlockwise and the bottom nut clockwise. Then move both locking nuts upward along the thread.

2

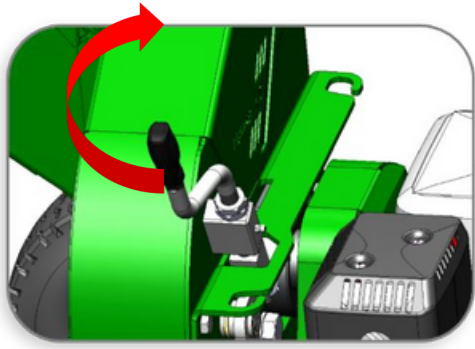

From the fully disengaged position, gently turn the engagement handle clockwise until you feel it start to resist. From this position, turn the engagement handle one full revolution clockwise. This is the recommended tension for the belt drive when in the fully engaged position.

3

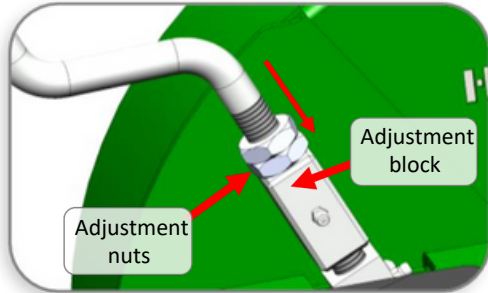

Using two 24 mm spanners, screw the two M16 adjustment nuts downwards until they touch the adjustment block. Then turn the top nut clockwise and the bottom nut anti clockwise simultaneously to lock the nuts in place.

Belt replacement

If the belts in your chipper look similar to any of the following images or are clearly broken, then they need to be replaced.

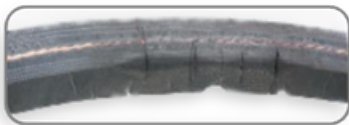

Cracked underside of belt

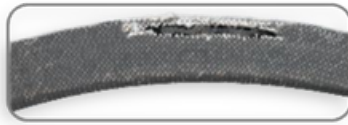

Split belt cover



Soft, swollen belt



Worn cover on back of belt



Sidewall belt wear

If a belt change is necessary, follow these steps:

1

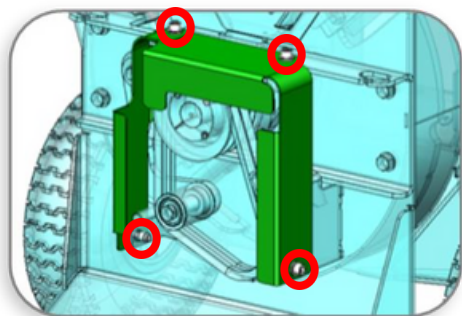

Using a 6 mm Allen key, unbolt and remove the pulley guard (4 x M8 cap screws).

Note: Engine not shown in this view.

2

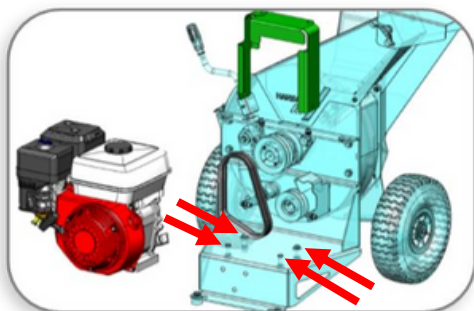

Using two 13mm spanners, unbolt and remove the engine (4 x M8 nuts and bolts).

Note: Loosen the belt tensioner to allow room for removal.

3



Remove old belts and replace (2 x A21 vee belts).

Note: The belts pass in between the idler wheel and belt guide on the tensioner arm.

4

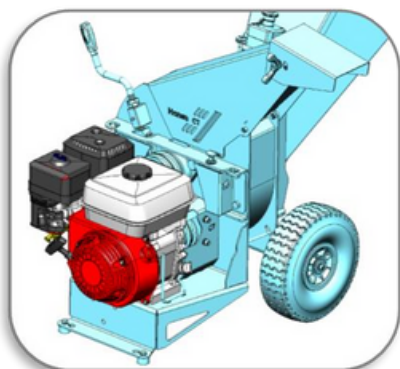

Place engine back in place and ensure the pulleys are in line.

5

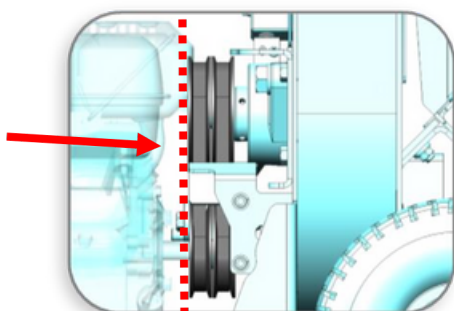

Fully tighten the four bolts holding the engine to the chassis. Check the pulleys are still in line by placing a straight-edge across the top and bottom front pulley. If they are not in line, loosen the four bolts holding the engine in to the chassis and then repeat this step.

6

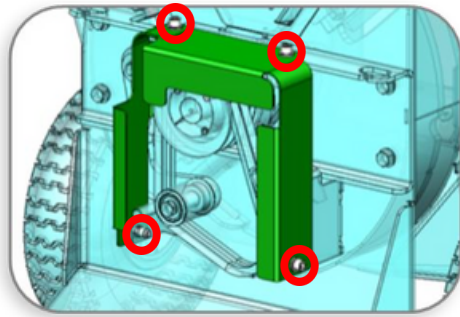

Ensure belts are properly tensioned (follow the 'Adjusting belt tension' process on page 17). Fasten the pulley guard back into place.

Note: Engine not shown in this view.

Note that after replacing a belt, the tension of the new belt will quickly change as the belt initially wears into the pulley system. Recheck the belt tension after two hours of operation after belt replacement.

Tyre pressure

The maximum recommended tyre pressure is 25 Psi. Over inflation may cause tyre to rupture.

Bolt torque

When servicing the machine, ensure any bolts you remove are done back up and torqued to the values listed in the torque table below:

		Relative Strength Bolt Marking			
		4.6		8.8	
		Recommended Tightening Torque		Recommended Tightening Torque	
Bolt size	Spanner size	lb ft	Nm	lb ft	Nm
M8	13 mm	6	8.5	16	22
M10	16 mm	12.5	17	32	44
M12	18 mm	22	30	57	77
M16	24 mm	54	73	140	190
M20	30 mm	105	143	274	372

Specifications





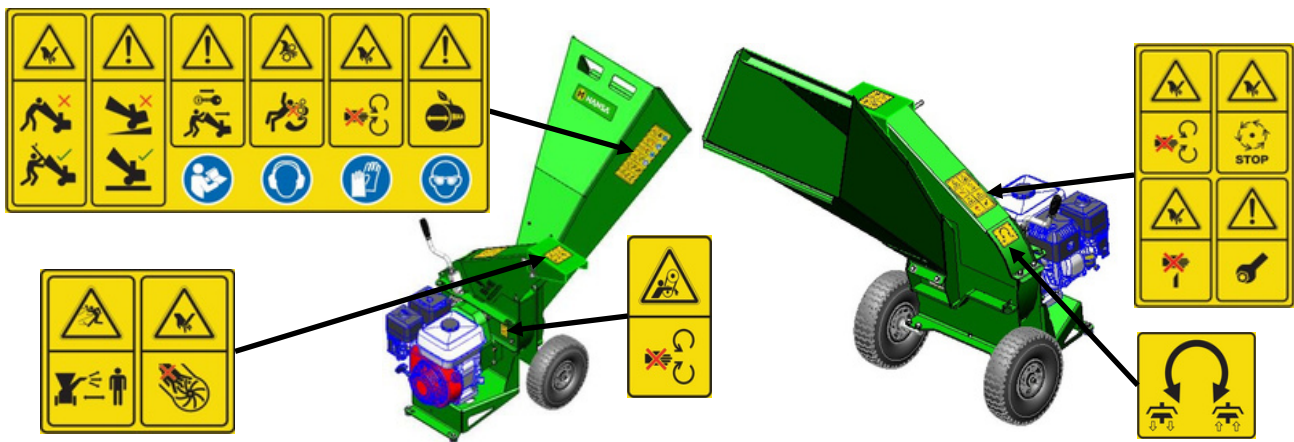

		C7
General	Length	1180 mm
	Width	805 mm
	Height	1250 mm
	Weight	93kg
Motor	Make & model	Honda GX200
	Max Power	6.5 HP
Cutting System	Disc speed	2850 RPM
	Disc dimensions	400 x 10 mm
	Shaft diameter	40 mm
	Knives	2
Feed System	Chipping capacity	70 mm
	Feed type	Gravity fed, self-feeding
	Inlet chute opening	130 x 150 mm
Discharge System	Discharge height	780 mm
	Outlet chute type	Fixed chute with deflector

Safety Labels



SafetyLabelLocations



Safety Label Explanations

						
Instructions manual must be read.	Ear protection must be worn.	Tight and heavy-duty gloves must be worn.	Eye protection must be worn.	Stay clear of outlet chute discharge area. Keep bystanders away.	Keep hands clear of outlet chute.	Keep clear while machine is running.

					
Use only wooden stick to clear blockage.	Operate only on stable level ground.	Turn machine off before moving.	Do not operate with loose clothing or long hair.	Do not extend hands down inlet chute past rubber flap.	Max 70mm branch capacity.

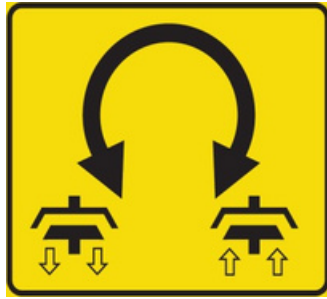
					
Do not open while machine is running.	Do not touch moving components.	Take care while working with sharp blades.	Fasten outlet before starting machine.	Turn anticlockwise to disengage.	Turn clockwise to engage.

HANSA global industrial limited warranty

For the purposes of this warranty document, "HANSA" means HANSA Products Limited and any of its international subsidiary companies. Refer to contact details below for further information.

HANSA warrants each new HANSA chipper ("HANSA product") free from defects in materials and workmanship under normal use and routine servicing, for the warranty periods and subject to the limitations and exclusions detailed below.

HANSA offers a special extended warranty period ("Extended Warranty") to new HANSA products purchased from an authorised HANSA dealer. The Extended Warranty period is set out below. In order to take advantage of the Extended Warranty you must:

1. Register your HANSA product through the HANSA warranty registration process and identify your HANSA product by its machine serial number. **Registration must be completed with ten (10) days from the date of purchase.** Your warranty registration confirmation email is your identification for warranty service; and
2. Have your registered HANSA product maintained in accordance with the schedule contained in the relevant owner's manual supplied with the product by an authorised HANSA dealer for the applicable territory. In order to ensure the safe operation of your HANSA product, we strongly recommend that you only use an authorised HANSA dealer for servicing. The cost of routine or required maintenance and services is the responsibility of the purchaser. You must keep a record of all service and maintenance history as proof of servicing history. HANSA may request such servicing history when assessing any future warranty claim.

When making a claim for warrantable repairs under the Extended Warranty, your warranty registration must accompany the HANSA product. If the warranty registration is lost or destroyed, proof of purchase documentation clearly recognising the machine serial number shall be accepted for warranty purposes. Where neither is available and HANSA does not have any record of the purchaser's details the warranty period shall be calculated from the appropriate dealer wholesale sale date. Any claim under the applicable Warranty must be made within the relevant warranty period specified below.

The Extended Warranty may be subject to cancellation if the above requirements are not satisfied.

The Extended Warranty is available to domestic (non-commercial) and commercial customers (excluding commercial customers in the business of plant/equipment hire).

All HANSA products that have not complied with the Extended Warranty registration and maintenance requirements are entitled to the "Non-Registered" warranty period set out below.

Any authorised HANSA dealer is further authorised to repair or replace any part which proves defective within the limits of the Extended Warranty or Non-Registered Warranty (the "Warranties") at no charge to the owner, covering parts and labour. Consumable items such as but not limited to oils, grease, blades and belts shall be the responsibility of the owner. All defective parts replaced under the Warranties become the property of HANSA.

You (as owner) are responsible for all shipping and transportation costs (including insurance) to and from an authorised HANSA dealer for the product subject to a warranty claim.

Exclusions

The warranties shall NOT APPLY TO:

- Any damage which results from neglect of periodic maintenance specified by HANSA. Any damage which results from repair or maintenance operations by methods other than specified by HANSA. Any damage which results from misuse or use beyond the limitations of the intended use specified by HANSA in the operation, maintenance and safety manual, such as overloading, including foreign objects such as stones, pieces of steel, glass etc. being dropped into the running machine or use under abnormal conditions (in HANSA's sole judgement). Any damage which results from use of non-genuine parts, lubricant or fluid not approved by HANSA. Any damage resulting from modification or installation in other products in a way not approved by HANSA which has any influence on the function and/or performance of the products. Any damage which results from operation other than specified in the Owner's Manual either intentionally or by error. Fading of painted surfaces, deterioration of plated surfaces, deterioration of rubber and plastics, including rusting due to the passage of time.
- Normal phenomena such as noise, vibration or oil seepage which are considered by HANSA as not affecting the quality, function or performance of the product.
- Any damage due to improper storage or transport.
- Consumable replacement items: Belts, cutting blades, anvil, serviceable bearings.
- Periodical maintenance items such as cleaning, inspection and adjustments.
- Any repair and/or adjustment performed by persons other than an authorised dealer, or damage resulting therefrom.
- Any repair and/or adjustment to correct improper or poor quality work previously performed

- Incidental expenses incurred in the warranty claim. For example: additional expenses such as those for towing, communications, hotel and meals, incurred due to breakdown of the product at a remote location. Any expense related to personal injury and/or property damage, (exclusive of the product itself). Compensation for loss of time, commercial losses or rental costs of a substitute product during the period of adjustment. Any damage which results from unavoidable natural disasters, fire, collision, theft, etc. Any normal wear or deterioration, such as that of sliding or rotating parts caused under normal operating conditions. For example: Normal wear pivot points, rod ends and bearings. Any damage resulting from exposure of the product to soot and smoke, medicines and chemical agents, sea water, sea breeze, salt or other environmental phenomena.

Limitations

- HANSA reserves the right to modify, alter and improve any product without incurring any obligation to replace any product previously sold with such modification.
- In no event shall HANSA’s liability exceed the purchase price of the product.
- Equipment and accessories not of HANSA’s manufacture (such as engine, battery and tires) are warranted only to the extent of the original manufacturer’s warranty and subject to their allowance to HANSA only if found to be defective by such manufacturer.
- HANSA reserves the right to supply remanufactured parts as it deems appropriate.

HANSA Product Warranty Period

HANSA CHIPPERS	COMMERCIAL		
	DOMESTIC	(EXCLUDING HIRE)	COMMERCIAL (HIRE)
Non-Registered	12 months	12 months	3 months
Extended Warranty	36 months (Conditional)*	36 months (Conditional)*	N/A

Each of the warranty periods stated above commence from the date on which you purchased your HANSA product.

*Conditional Warranty:

This is a HANSA extended warranty period for products that are:

- Purchased from an authorised HANSA Dealer.
- Registered at the time of sale through the Hansa Chippers website: www.hansaproducts.com/registration
- Serviced by a HANSA Dealer in accordance with the Hansa service schedule using genuine HANSA parts.
- Extended Warranty is limited to 36 months or 1000 hours, whichever occurs first.
- Meeting all other warranty requirements.

Warranty periods vary depending on whether the purchaser is: (i) a domestic (i.e. non-commercial) customer; (ii) commercial customer (excluding plant/equipment hire businesses); or (iii) a commercial customer in the business of plant/equipment hire.

General

- Your rights:
 - HANSA will recognise any implied rights and remedies that are available to you at law in the applicable territory and that cannot be excluded by HANSA.
 - In New Zealand, Hansa Products Ltd will recognise your statutory rights under the Consumers Guarantee Act 1993 (provided that you are a consumer for the purposes of that Act).
 - In Australia, this warranty is given by Hansa Products Pty Ltd. This warranty is provided in addition to other rights and remedies you have under law - our HANSA products come with guarantees that cannot be excluded under the Australian Consumer Laws.
- If any provision of this warranty document is held by any competent authority to be invalid or unenforceable in whole or in part, the validity of the other provisions of this warranty document and the remainder of the provisions in question will not be affected. The English language version of this warranty document prevails over any translated version/s of its terms.
- warranty document is governed by the laws of New Zealand. The parties submit to the exclusive jurisdiction of the New Zealand Courts.

Contact Details

New Zealand:

Hansa Products Limited
PO Box 10323, Te Rapa

Rest of World:

Please refer to www.hansaproducts.com
for a current list of our authorised dealers

Commissioning checklist and registration



It is the retailers' responsibility to ensure that this chipper is correctly commissioned for use, and that the purchase is registered with Hansa Chippers so as to provide the owner with the full benefit of the warranty policy.

Product registration must be completed online:

www.hansaproducts.com/registration

For registration, you will require the chipper serial number and customer details.

It is the retailers' responsibility to check the following:

Final Assembly	Check all bolts for tightness including knives
Operation	Instruct the owner/operator on operating procedures and techniques
Safety	Instruct owner/operator on safety procedures
Maintenance	Explain the maintenance requirements and the importance of following the maintenance schedule to the owner/operator
Manual	Emphasise the importance of reading and understanding the manual in full before initial operation of the chipper